

H	Overlay					P	S
0	14	15	16	17	18	12	21.5
3	11	12	13	14	15	15	24.5
4.5	9.5	10.5	11.5	12.5	13.5	16.5	26
6	8	9	10	11	12	18	27.5
9	5	6	7	8	9	21	30.5
	3	4	5	6	7	Fixed distance = 11	
	B = boring distance						

NOTE: 4.5 plate is only for use in frame cabinets, 9 plate is only for panel cabinets

Abbreviations	
H	= Plate height
P	= Door protrusion
S	= Side arm protrusion
W	= Side panel width

SKU: B71T3580



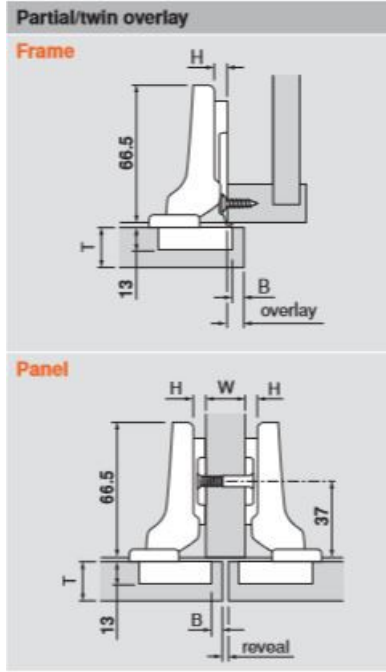

H	Overlay					P	S	
0	4.5	5.5	6.5	7.5	8.5	21.5	31	
	3	4	5	6	7	Fixed distance = 1.5		
	B = boring distance							
H	Reveal					W	P	S
	7	5	3	1	-	16		
0	10	8	6	4	2	19	21.5	31
	13	11	9	7	5	22		
	3	4	5	6	7			
	B = boring distance							

Abbreviations	
H	= Plate height
P	= Door protrusion
S	= Side arm protrusion
W	= Side panel width

SKU: B71T3680



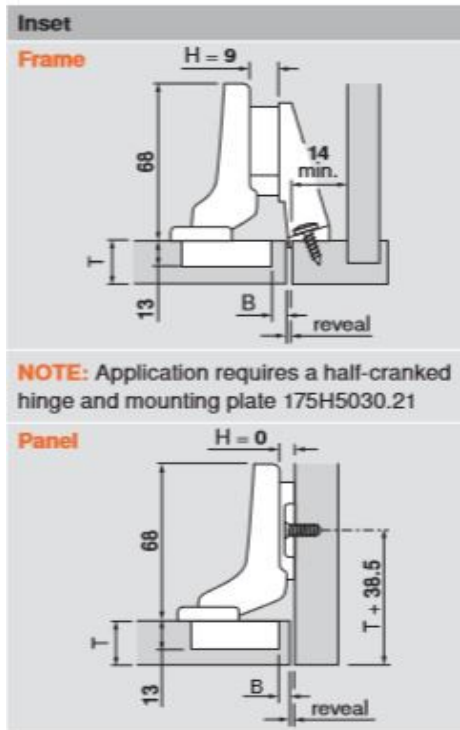

NOTE: Application requires a half-cranked hinge and mounting plate 175H5030.21

H	Reveal					P	S	
0	4	3	2	1	-	30	39.5	
9	4.5	3.5	2.5	1.5	0.5	30.5	40	
	3	4	5	6	7	Fixed distance: 0 = -7 9 = 1.5		
B = boring distance								

Abbreviations

H	=	Plate height
P	=	Door protrusion
S	=	Side arm protrusion
W	=	Side panel width

SKU: B71T3780

