



TRADEMARK HARDWARE

WORLD OF QUALITY HARDWARE

FALCON XX-V; F-XX-V EXIT DEVICE INSTALLATION

2) TO CHANGE FROM STANDARD LOCKING TRIM TO EITHER NIGHTLATCH FUNCTION OR BLANK ESCUTCHEON, FOLLOW THE PROCEDURE BELOW:

A) FOR NIGHTLATCH FUNCTION:

- 1) REMOVE AXLE SUPPORT ASSEMBLY (WITH AXLE AND CROSSBAR ARM) FROM CHASSIS (4 SCREWS NOT SHOWN).
- 2) REMOVE SLIDEBAR (NOT SHOWN).
- 3) REMOVE RETAINING RING FROM LOCKING CAM OPERATOR (ON BACKSIDE OF ACTIVE HEAD).
- 4) TURN LOCKING CAM OPERATOR SO THAT TAB ON OPERATOR FITS INTO RECTANGULAR SLOT IN LOCKING CAM (SEE BELOW) AND REATTACH RETAINING RING TO LOCKING CAM OPERATOR.
- 5) REPLACE SLIDEBAR (NOT SHOWN).
- 6) REATTACH AXLE SUPPORT ASSEMBLY (WITH AXLE AND CROSSBAR ARM) TO CHASSIS (4 SCREWS NOT SHOWN).
- 7) CONTINUE WITH DEVICE INSTALLATION.

B) FOR BLANK ESCUTCHEON DEVICES:

- 1) REMOVE AXLE SUPPORT ASSEMBLY (WITH AXLE AND CROSSBAR ARM) FROM CHASSIS (4 SCREWS NOT SHOWN).
- 2) REMOVE SLIDEBAR (NOT SHOWN).
- 3) REMOVE RETAINING RING FROM LOCKING CAM OPERATOR (ON BACKSIDE OF ACTIVE HEAD). REMOVE LOCKING CAM AND LOCKING CAM OPERATOR FROM ACTIVE HEAD.
- 4) IF DEVICE IS (F)XX-V-TP, GO TO STEP 9; IF DEVICE IS (F)XX-V-KL, CONTINUE TO STEP 5.
- 5) REMOVE RETAINING RING FROM KNOB HUB AND REMOVE KNOB HUB.
- 6) USING PUNCH, DRIVE OUT RIVETS (FROM BACKSIDE) HOLDING LOCKING PLATE TO CHASSIS.
- 7) REMOVE LOCKING PLATE.
- 8) REPLACE KNOB HUB USING RETAINING RING.
- 9) REPLACE SLIDEBAR (NOT SHOWN).
- 10) REATTACH AXLE SUPPORT ASSEMBLY (WITH AXLE AND CROSSBAR ARM) TO CHASSIS (4 SCREWS NOT SHOWN).
- 11) CONTINUE WITH DEVICE INSTALLATION.

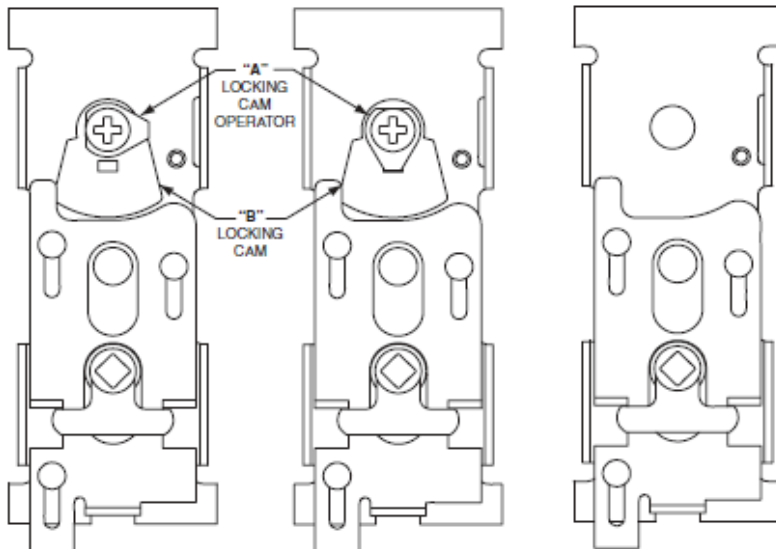

'L' AND 'K'
COVER PLATE ASSEMBLY
FIGURE 1

'L-NL' AND 'K-NL' (NIGHT LATCH)
COVER PLATE ASSEMBLY
FIGURE 2

'L-BE' AND 'K-BE'
(BLANK ESCUTCHEON)
COVER PLATE ASSEMBLY
FIGURE 3

F-XX-V & XX-V EXIT DEVICES

INSTALLATION INSTRUCTIONS

1 PARTS CHECK

- 1) MAKE SURE THE CORRECT DEVICE IS BEING USED, AND IS THE CORRECT HANDING (SEE PAGE #14 FOR REVERSING INSTRUCTIONS).
- 2) MAKE SURE ALL NEEDED PARTS ARE ON HAND.
NOTE: LIST DOES NOT REFLECT ALL POSSIBLE APPLICATIONS.

<p>1) (F) XX-V DEVICE AND CROSSBAR</p> <p><i>NOTE: DEVICE IS FIELD REVERSIBLE</i></p>	<p>3) LATCHES & BOTTOM BOLTS</p> <p>TOP LATCH </p> <p>BOTTOM BOLT </p>																				
<p>2) STRIKE</p> <p>4163/3788 2130 4155</p> <table border="0"> <tr> <td>FIRE</td> <td>TOP</td> <td>(F)XX-V</td> <td></td> </tr> <tr> <td></td> <td>BOTTOM</td> <td>3788</td> <td></td> </tr> <tr> <td>PANIC</td> <td>TOP</td> <td>4163</td> <td></td> </tr> <tr> <td></td> <td>BOTTOM</td> <td>2130</td> <td></td> </tr> <tr> <td>OPT.</td> <td>BOTTOM</td> <td>4155</td> <td></td> </tr> </table>	FIRE	TOP	(F)XX-V			BOTTOM	3788		PANIC	TOP	4163			BOTTOM	2130		OPT.	BOTTOM	4155		<p>4) SCREW PACK FOR PANIC DEVICE</p> <p>DOGGING I Y (1 QTY) </p> <p>#10x1-1/4" FPHSMS (6 QTY (2 FINISHED)) </p> <p>#10x1-1/4" PPHSM (12 QTY) </p> <p>1/8"x1" COTTER K (1 QTY) </p> <p>ROD GUIDE COVER (2 QTY) </p> <p>ROD GUIDE BRACKET (2 QTY) </p> <p>ROD GUIDE INSERT (2 QTY) </p> <p>#8-32x1/4" UPPHMS (4 FINISHED) </p> <p>5) SCREW PACK FOR FIRE DEVICE</p> <p>#10-24x3/4" FPHMS (6 QTY) </p> <p>#10-24x3/4" PPHMS (12 QTY) </p> <p>1/8"x1" COTTER KEY (1 QTY) </p> <p>ROD GUIDE COVER (2 QTY) </p> <p>ROD GUIDE BRACKET (2 QTY) </p> <p>ROD GUIDE SUPPORT (2 QTY) </p> <p>#8-32x1/4" UPPHMS (4 FINISHED) </p>
FIRE	TOP	(F)XX-V																			
	BOTTOM	3788																			
PANIC	TOP	4163																			
	BOTTOM	2130																			
OPT.	BOTTOM	4155																			
<p>6) VERTICAL RODS (LENGTHS FOR 70" OPENINGS)</p> <p>TOP ROD = 35"</p> <p>BOTTOM ROD = 36-1/2" (WITH DEAD BOLT)</p>																					

3) MAKE SURE OUTSIDE TRIM (IF BEING USED) HAS BEEN PROVIDED AND IS THE CORRECT HANDING. SEE PAGE #15 FOR LOCKING CAM AND LOCKING CAM OPERATOR POSITION.

Customer Service

1-877-671-7011 www.allegion.com/us



ALLEGION®

© Allegion 2014
Printed in U.S.A.
D-1015 Rev. 07/14-b

sales@tmhardware.com

845-388-1388



**TRADEMARK
HARDWARE**

WORLD OF QUALITY HARDWARE

FALCON XX-V; F-XX-V EXIT DEVICE INSTALLATION

2 DOOR LAYOUT

(NOTE: FOR FACTORY PREPARED DOORS, VERIFY LAYOUT.)

- 1) DOOR MUST BE FITTED AND HUNG PROPERLY BEFORE PROCEEDING.
- 2) MARK VERTICAL ϵ AND DEVICE REF. ϵ ON DOOR AND FRAME (SEE FIGURES & CHART BELOW).

A) VERTICAL ϵ :

INSTALLATION	PANELED DOOR	FLUSH DOOR	MINIMUM STILE
SINGLE: (F)XX-V	"A" = 1/2 OF STILE	"A" = 2-3/4"	2-3/4"
PAIR: (F)XX-V	"B" = 1/2 OF STILE	"B" = 2-3/4"	
(F)XX-V x (F)XX-M WITH OPEN BACK STRIKE	"C" = 2-3/4"	"C" = 2-3/4"	4-1/2"
XX-V x XX-H WITH 571 STRIKE	"D" = 2-3/4"	"D" = 2-3/4"	3-7/8"
XX-V x XX-R WITH 571A STRIKE	"D" = 2-1/4"	"D" = 2-1/4"	3-3/8"

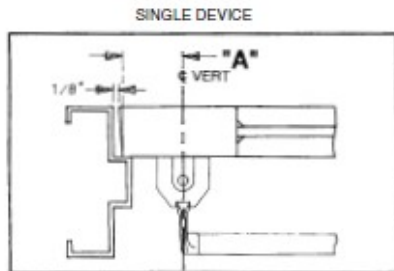

SINGLE DEVICE
VERTICAL ROD x RIM DEVICE
(571 OR 571A REQUIRED FOR THIS APPLICATION)

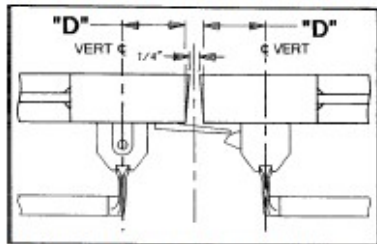

NOTE: 571 AND 571A ARE NOT APPROVED FOR FIRE RATED APPLICATIONS

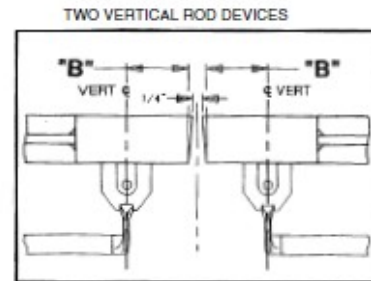

TWO VERTICAL ROD DEVICES
VERTICAL ROD x MORTISE DEVICE
(OPEN BACK STRIKE REQUIRED FOR MORTISE DEVICE IN THIS APPLICATION)

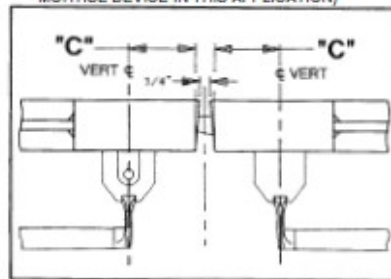

PAGE 2

6 LOCKING FUNCTIONS

- 1) IF USING STANDARD LOCKING TRIM, ROTATE LOCKING CAM OPERATOR COMPLETELY TO FULLY-LOCKED POSITION AS SHOWN IN THE FIGURES BELOW. THIS WILL ENSURE PROPER TIMING BETWEEN THE LOCKING FEATURE AND THE CYLINDER.

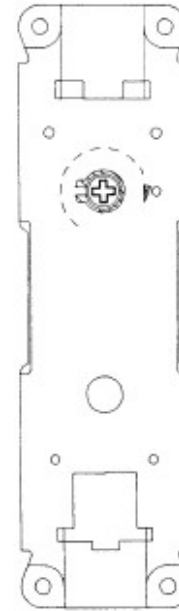

BACKSIDE VIEW OF (F)XX-V DEVICE

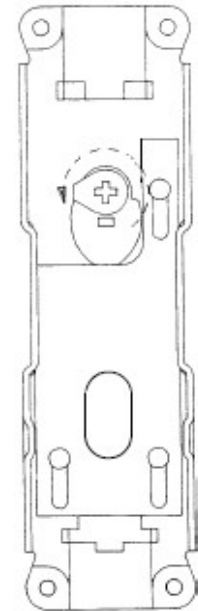

FRONTSIDE VIEW OF (F)XX-V DEVICE
SHOWN WITHOUT AXLE SUPPORT AND
SLIDEBAR FOR CLAIRITY

PAGE 15



**TRADEMARK
HARDWARE**

WORLD OF QUALITY HARDWARE

FALCON XX-V; F-XX-V EXIT DEVICE INSTALLATION

5 REVERSING INSTRUCTIONS

TO REVERSE THE HANDING OF A (F)XX-V DEVICE

NOTE: DEVICES WITH CYLINDER DOGGING CANNOT BE REVERSED

- 1) REMOVE CHASSIS COVER FROM BOTH HEADS (4 SCREWS EACH).
- 2) REMOVE AXLES FROM BOTH ACTIVE AND INACTIVE HEADS.
- 3) SWAP CROSSBAR ARMS FROM ACTIVE HEAD TO INACTIVE HEAD.
- 4) REINSERT AXLES INTO BOTH ACTIVE AND INACTIVE HEADS.
- 5) PROCEED WITH INSTALLATION.

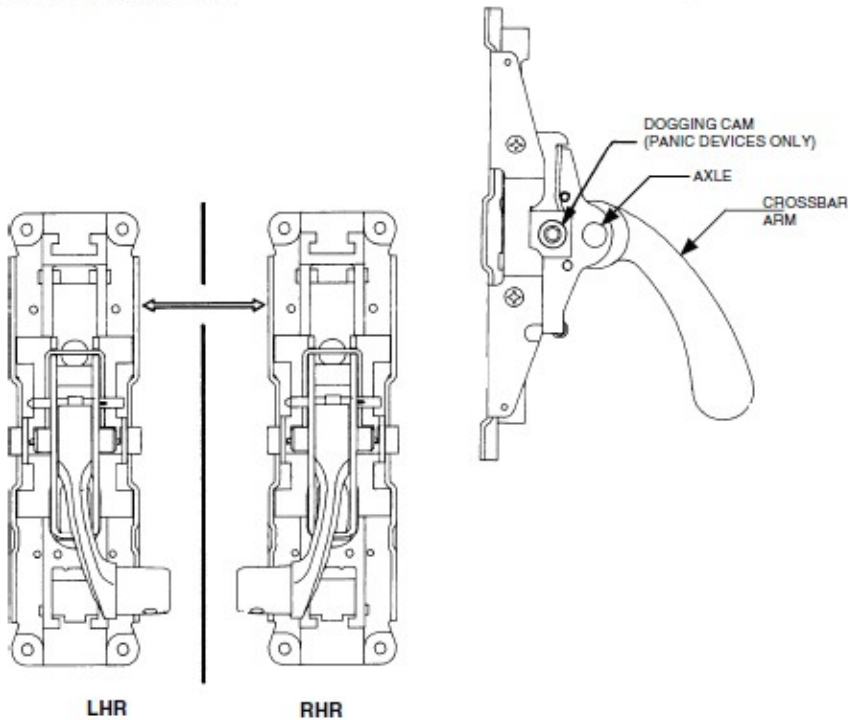

FRONT VIEW OF ACTIVE HEAD SHOWN

B) DEVICE REF. \bar{C} (HORIZONTAL).

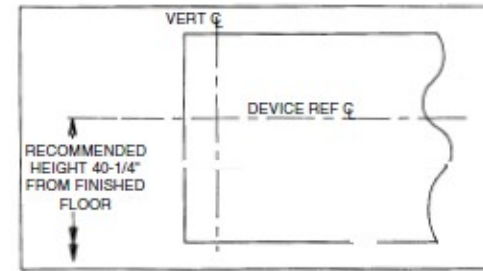

3 DOOR & HARDWARE PREPARATION

- 1) CHOOSE CORRECT DRILLING TEMPLATES FROM THE CENTER OF THIS BOOK.
- 2) TAPE DRILLING TEMPLATE ON DOOR USING VERTICAL \bar{C} AND DEVICE REF. \bar{C} (REFER TO 2).

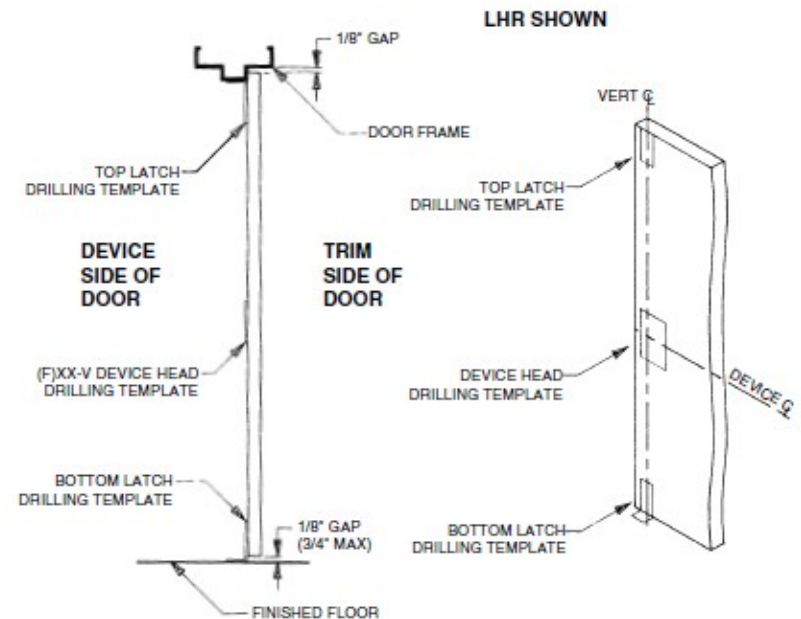



TRADEMARK HARDWARE

WORLD OF QUALITY HARDWARE

FALCON XX-V; F-XX-V EXIT DEVICE INSTALLATION

3) PREPARE HOLES FOR DEVICE, STRIKE AND LATCHES. FOR DEVICES WITH TRIM FUNCTIONS, PREPARE THE HOLE(S) ON THE DEVICE TEMPLATE DESCRIBED IN THE CHART BELOW. AFTER DRILLING HOLES, REMOVE THE DRILLING TEMPLATE.

DEVICE FUNCTION	DRILLING TEMPLATE HOLES
(F)XX-V-N	NONE
(F)XX-V-C (CYL. ONLY)	B
(F)XX-V-NL	B
(F)XX-V-TP	A, D
(F)XX-V-DT	NONE
(F)XX-V-K	A, C
(F)XX-V-L	A, C
(F)XX-V-TL	NONE

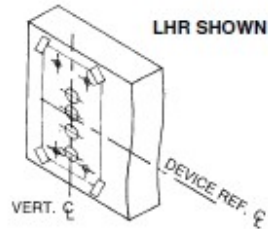

4) IF USING OUTSIDE TRIM, PREPARE DOOR USING SEPARATE TRIM DIRECTION SHEET. FOR SEXBOLT INSTALLATIONS, DRILL 3/8" DIAMETER HOLES ON TRIM SIDE OF DOOR ONLY (SEE DIAGRAM BELOW).

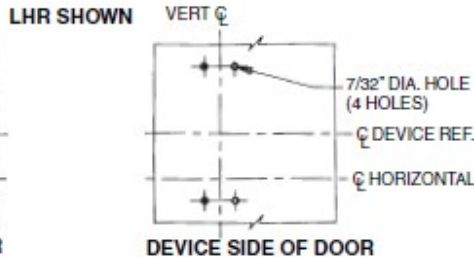
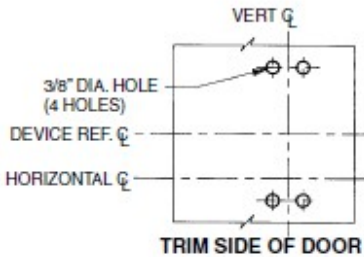

5) DETERMINE CROSSBAR LENGTH.

- MEASURE DISTANCE BETWEEN VERTICAL Ø AND EDGE OF DOOR.
- CALCULATE CROSSBAR LENGTH "X" USING FORMULA BELOW.

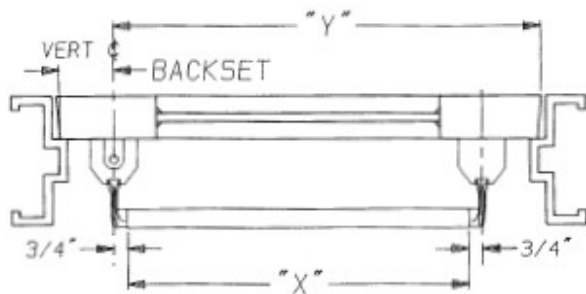

$$"X" = "Y" - \text{BACKSET} - 1-1/2"$$

12) ATTACH CHASSIS COVER.

- REMOVE AXLES FROM BOTH ACTIVE AND INACTIVE CHASSIS.
- REMOVE CROSSBAR AND CROSSBAR ARMS FROM BOTH CHASSIS.
- SLIDE CROSSBAR ARMS INTO RECTANGULAR CUT-OUT IN TOP OF CHASSIS COVER.
NOTE: THE 1/2" DIA. HOLE IN THE CHASSIS COVER ON BOTH COVERS SHOULD FACE EACH OTHER.
- INSERT CROSSBAR ARMS INTO CHASSIS AND INSERT AXLES.
- SLIDE CHASSIS COVER OVER CHASSIS AND ATTACH WITH 4 (PER HEAD) #8-32x1/4" UPPHMS.

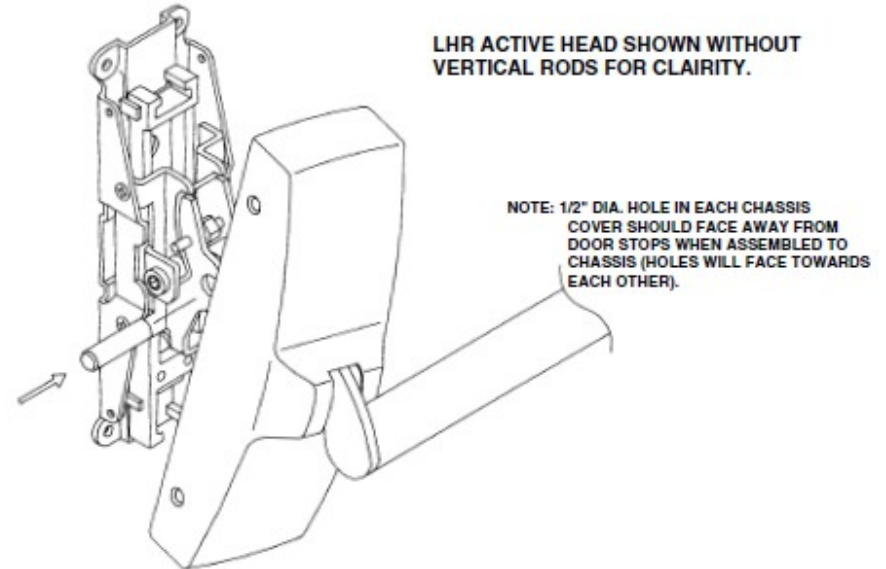

13) CHECK DOGGING OPERATION (PANIC OPERATION ONLY).

- DEPRESS CROSSBAR, INSERT AND TURN DOGGING KEY IN BOTH ACTIVE AND INACTIVE HEADS.
- REMOVE DOGGING KEY, CROSSBAR SHOULD REMAIN DEPRESSED.
- REINSERT DOGGING KEY AND TURN IN OPPOSITE DIRECTION (BOTH HEADS). CROSSBAR WILL SWING OUT.
- FOR CYLINDER DOGGING, REFER TO INSTALLATION D-4085.

14) CHECK FOR SMOOTH OPERATION AND SECURE LATCHBOLT ENGAGEMENT. ADJUST STRIKE IF REQUIRED.



**TRADEMARK
HARDWARE**

WORLD OF QUALITY HARDWARE

FALCON XX-V; F-XX-V EXIT DEVICE INSTALLATION

11) APPLY STRIKES AND COVERS.

- A) ATTACH TOP AND BOTTOM LATCH COVERS USING (2) #8-32x1/4" UFPHMS SCREWS.
- B) INSTALL STRIKES TO TOP OF DOOR FRAME AND TO FLOOR OR THRESHOLD.

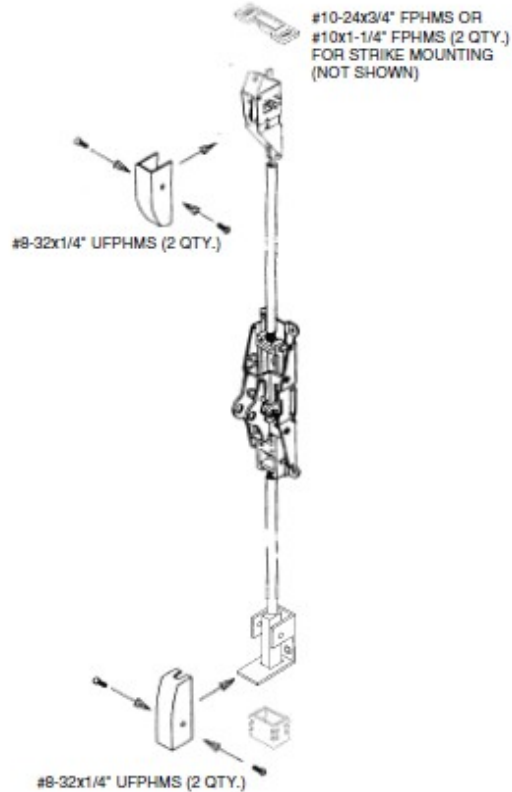

DEVICES SHOWN WITHOUT
CROSSBAR ARMS FOR CLAIRITY.

6) IF CROSSBAR IS LONGER THAN "X", CUT THE CROSSBAR TO THE CORRECT LENGTH.

- A) MARK CROSSBAR TO LENGTH "X".

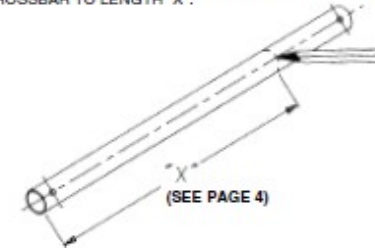

- B) CUT CROSSBAR TO MARKED DIMENSION AND REMOVE BURRS.

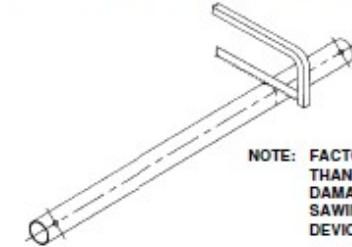

NOTE: FACTORY RECOMMENDS SAWING RATHER THAN GRIND CUT TO SIZE. GRINDING CAN DAMAGE THE FINISH OF THE DEVICE AND SAWING RESULTS IN LESS DAMAGE TO THE DEVICES'S FINISH.

- C) DRILL A 5/16" DIA. HOLE 5/8" FROM THE JUST CUT END OF THE CROSSBAR.

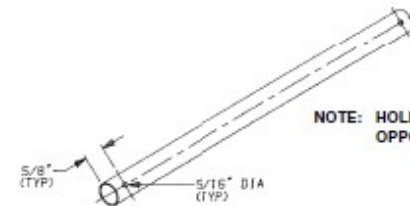

NOTE: HOLE SHOULD BE IN-LINE WITH HOLE AT OPPOSITE END OF THE CROSSBAR.

7) IF DOOR OPENING IS NOT 70", DETERMINE TOP ROD LENGTH BASED ON A 40-1/4" DEVICE REF. C FROM FINISHED FLOOR.

- A) FOR DOOR OPENINGS UNDER 70":
 - 1) SUBTRACT DOOR OPENING FROM 70" OPENING.
 - 2) SUBTRACT ANSWER FROM PART 1 FROM 35" TO DETERMINE TOP ROD LENGTH. (EXAMPLE: 6'8" OPENING - 70"-6'8"= 4", 35"-4"=31" TOP ROD).
- B) FOR DOOR OPENINGS ABOVE 70":
 - 1) SUBTRACT 70" FROM DOOR OPENING.
 - 2) ADD ANSWER FROM PART 1 TO 35" TO DETERMINE TOP ROD LENGTH. (EXAMPLE: 8'10" OPENING - 8'10"-7'0" = 22", 35"+22"= 57" TOP ROD).

PAGE 5

PAGE 12



TRADEMARK HARDWARE

WORLD OF QUALITY HARDWARE

FALCON XX-V; F-XX-V EXIT DEVICE INSTALLATION

8) MODIFY TOP ROD TO REQUIRED LENGTH.

A) FOR TOP RODS THAT ARE TOO LONG, FOLLOW PROCEDURE BELOW TO CUT ROD TO SIZE.

1) MARK RODS TO REQUIRE LENGTH.

NOTE: ROD MUST BE MEASURED FROM THREADED PORTION OF ROD.

DO NOT CUT ROD AT END WITH INTERNAL THREADS.

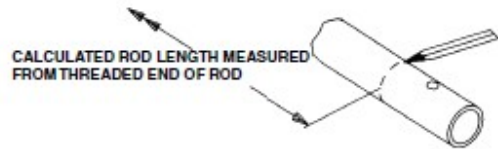

CALCULATED ROD LENGTH MEASURED
FROM THREADED END OF ROD

2) CUT ROD AT MARKED LOCATION.



3) DRILL COTTER KEY CONNECTION HOLE.

DRILL 1/8" DIA. HOLE THRU ON VERTICAL ROD 7/16" FROM END OF ROD JUST CUT.

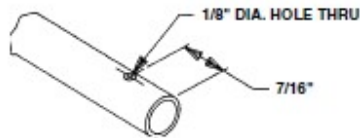

1/8" DIA. HOLE THRU

7/16"

B) FOR RODS THAT ARE TOO SHORT, FOLLOW PROCEDURE BELOW.

1) ATTACH EXTENSION RODS TO THREADED SECTION OF TOP ROD.



TOP ROD

EXTENSION ROD

2) FOLLOW INSTRUCTIONS TO MARK, CUT & DRILL TOP ROD (SEE ABOVE).

11) INSTALL ROD GUIDE COVER.

A) SLIDE ROD GUIDE INSERT INTO ROD GUIDE BRACKET.

B) PLACE ROD GUIDE COVER OVER ROD GUIDE INSERT.

C) INSTALL ROD GUIDE COVER TO ROD GUIDE BRACKET USING #8-32x1/4" UPPHMS (2 QTY, PER ROD GUIDE).

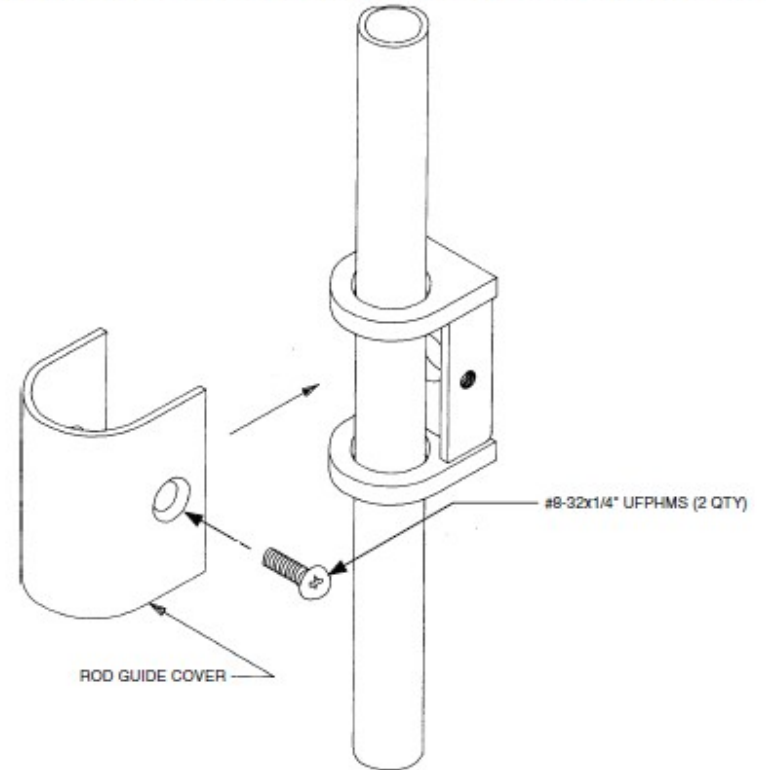

#8-32x1/4" UPPHMS (2 QTY)

ROD GUIDE COVER





TRADEMARK HARDWARE

WORLD OF QUALITY HARDWARE

FALCON XX-V; F-XX-V EXIT DEVICE INSTALLATION

10) VERTICAL ROD ADJUSTMENT

A) TOP ROD ADJUSTMENT WITH DOOR OPEN.

- 1) RELEASE TOP LATCH BOLT USING RELEASE TRIGGER.
- 2) CHECK TOP LATCHBOLT PROJECTION, LATCHBOLT PROJECTION SHOULD BE 5/8" TO 3/4".
- 3) IF THE TOP LATCH BOLT DOES NOT PROJECT THIS MUCH, SWING OUT THE TOP ROD FROM THE BRASS SLIDEBAR AND TURN THE ADJUSTMENT SCREW ONE FULL TURN (SEE BELOW). RETURN THE ROD TO THE SLIDEBAR AND RECHECK THE LATCH BOLT PROJECTION. REPEAT UNTIL TOP LATCH BOLT PROJECTION IS 5/8" TO 3/4".
- 4) SLOWLY DEPRESS THE TOUCHBAR AND RELEASE, THE LATCH BOLT SHOULD REMAIN IN THE RETRACTED POSITION.
- 5) IF THE LATCH BOLT DOES NOT REMAIN RETRACTED, DECREASE TOP LATCH BOLT PROJECTION BY ROTATING THE ADJUSTMENT SCREW ONE-HALF TURN (SEE BELOW).
- 6) REPEAT PROCESS UNTIL LATCHBOLT REMAINS IN RETRACTED POSITION.

B) BOTTOM BOLT ADJUSTMENT WITH DOOR OPEN AND TOP LATCH BOLT SHOULD REMAIN IN THE RETRACTED POSITION.

- 1) ROTATE ROD TO ALLOW BOTTOM BOLT TO CLEAR FINISHED FLOOR. (SEE BELOW).

C) IF TRIM IS BEING USED, RELEASE TOP LATCH BOLT USING RELEASE TRIGGER, OPERATE TRIM AND CHECK FOR FULL LATCH BOLT RETRACTION. IF TOP LATCH BOLT DOES NOT REMAIN IN RETRACTED POSITION, DECREASE TOP LATCH BOLT PROJECTION (SEE BELOW).

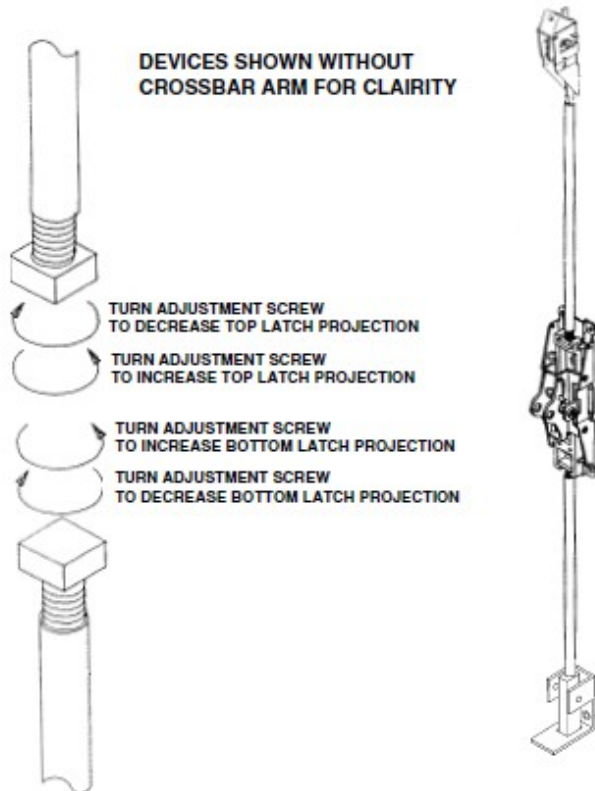

DEVICES SHOWN WITHOUT
CROSSBAR ARM FOR CLAIRITY

TURN ADJUSTMENT SCREW
TO DECREASE TOP LATCH PROJECTION

TURN ADJUSTMENT SCREW
TO INCREASE TOP LATCH PROJECTION

TURN ADJUSTMENT SCREW
TO INCREASE BOTTOM LATCH PROJECTION

TURN ADJUSTMENT SCREW
TO DECREASE BOTTOM LATCH PROJECTION

PAGE 10

4 HARDWARE INSTALLATION

- 1) IF USING OUTSIDE TRIM OR SEXBOLTS, MOUNT TRIM PER DIRECTIONS IN TRIM BOX, OR INSTALL OUTSIDE SEX BOLTS.
- 2) EITHER SURFACE MOUNT DEVICE, OR THROUGH-BOLT DEVICE TO TRIM OR SEXBOLTS (NOTE: FOR LOCKING TRIM, SEE PAGE #15 FOR LOCKING CAM AND LOCKING CAM OPERATOR POSITION).

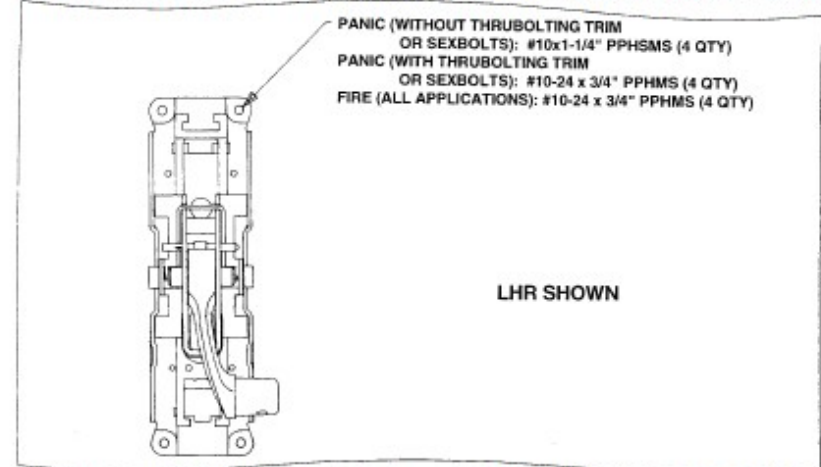

- 3) REMOVE CROSSBAR RETAINER SCREW AND ROUNDED WASHER FROM XX CROSSBAR ARMS. SLIDE THE CROSSBAR OVER BOTH THE ACTIVE AND INACTIVE ARMS AND ATTACH WITH CROSSBAR RETAINER SCREW AND ROUNDED WASHER.

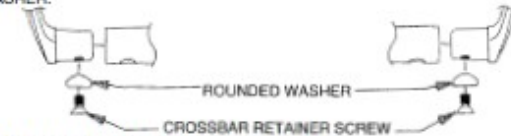

- 4) LOCATE, MARK, AND DRILL INACTIVE HEAD MOUNTING HOLES.

- A) LEVEL CROSSBAR ON DOOR AND MARK CENTER OF FOUR MOUNTING HOLES.
- B) DRILL 9/64" DIA. HOLES IF USING SHEET METAL SCREWS OR DRILL & TAP #10-24 IF USING MACHINE SCREWS OR DRILL 1/4" DIA. HOLE INSIDE AND 3/8" DIA. HOLE OUTSIDE FOR SEXBOLTS.

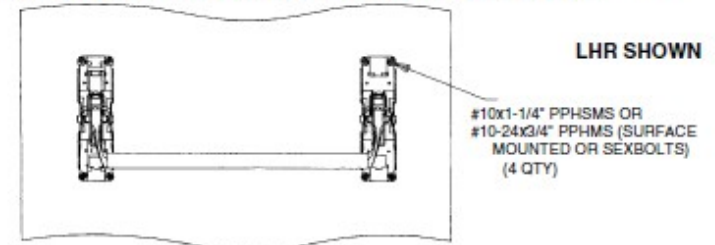

PAGE 7





TRADEMARK HARDWARE

WORLD OF QUALITY HARDWARE

FALCON XX-V; F-XX-V EXIT DEVICE INSTALLATION

- 5) TIGHTEN ALL DEVICE MOUNTING SCREWS.
- 6) INSTALL TOP AND BOTTOM LATCHES.

PANIC DEVICES

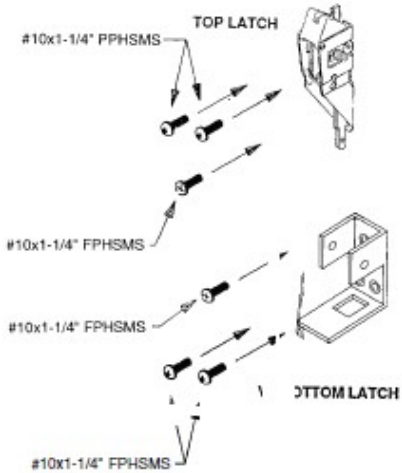

FIRE DEVICES

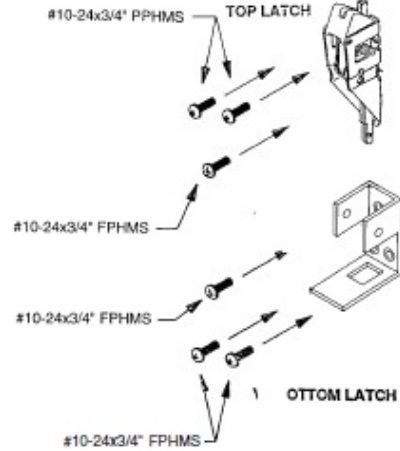

- 7) ATTACH ROD GUIDE BRACKETS TO DOOR ON VERTICAL C EQUIDISTANT BETWEEN THE LATCHES AND DEVICE HEAD.

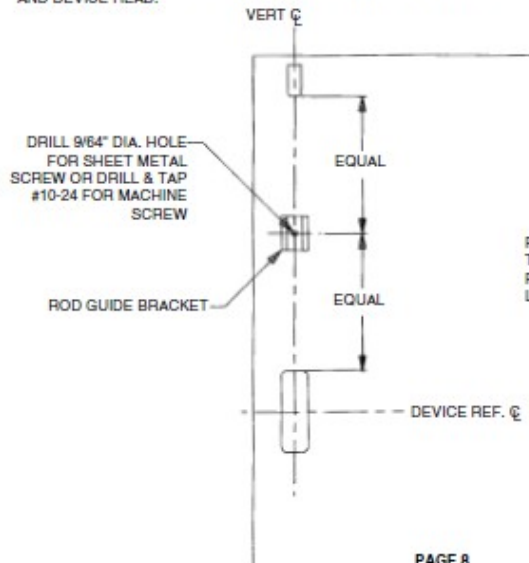

FOR DEVICES ON DOORS OVER 8'0" TALL, TWO ROD GUIDE BRACKETS SHOULD BE PLACED EQUALLY BETWEEN THE TOP LATCH AND DEVICE HEAD.

PAGE 8

- 8) SLIDE TOP ROD THROUGH ROD GUIDE INSERT AND THEN ATTACH TO TOP LATCH USING 1/8"x1" COTTER KEY. BEND COTTER KEY. UNSCREW ADJUSTMENT SCREW FROM BOTTOM ROD WITH BOLT AND SLIDE ON ROD GUIDE INSERT, RE-SCREW THE ADJUSTMENT SCREW TO THE BOTTOM ROD, THEN INSERT BOTTOM BOLT THROUGH BOTTOM BOLT GUIDE AND PLACE ADJUSTMENT SCREW INTO BRASS SLIDEBAR.

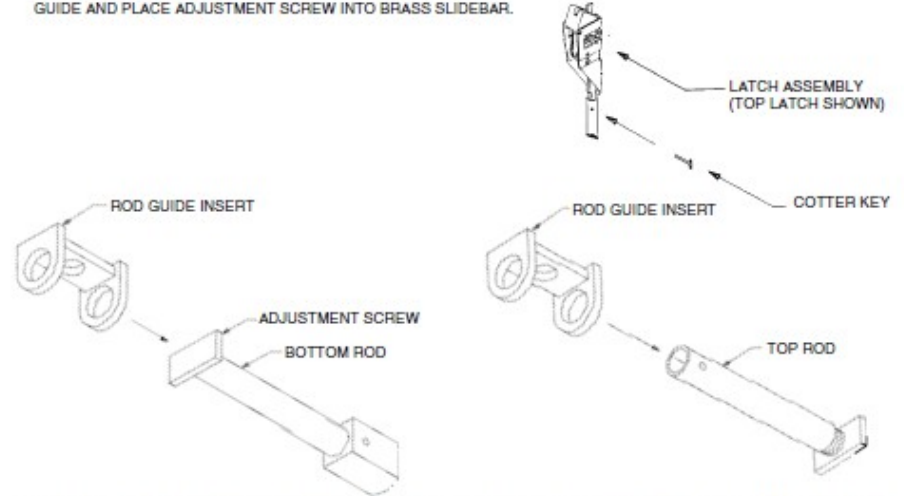

- 9) TURN ADJUSTMENT SCREW UNTIL IT IS APPROXIMATELY 1/2" INTO THE VERTICAL ROD. SWING RODS SO THAT THE ADJUSTMENT SCREW IS IN THE BRASS SLIDEBAR IN THE ACTIVE HEAD AS SHOWN BELOW.

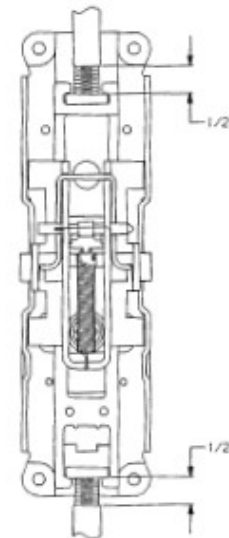

(F)XX-V DEVICE ACTIVE HEAD SHOWN WITHOUT CROSSBAR ARM FOR CLAIRITY.

PAGE 9



XX SERIES SURFACE VERTICAL ROD PANIC AND FIRE EXIT DEVICES DRILLING TEMPLATE

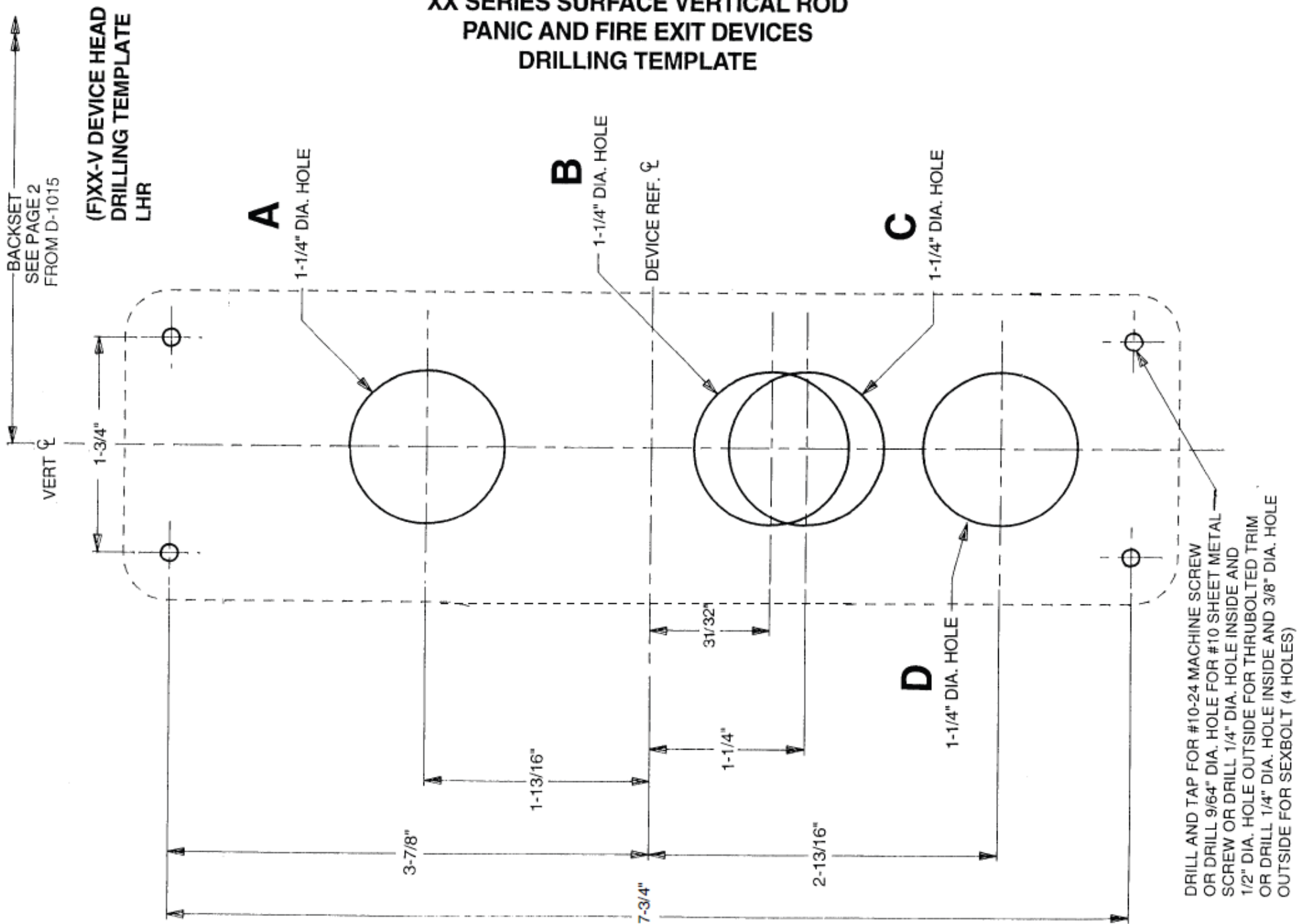

**(F)XX-V DEVICE HEAD
DRILLING TEMPLATE
RHR**

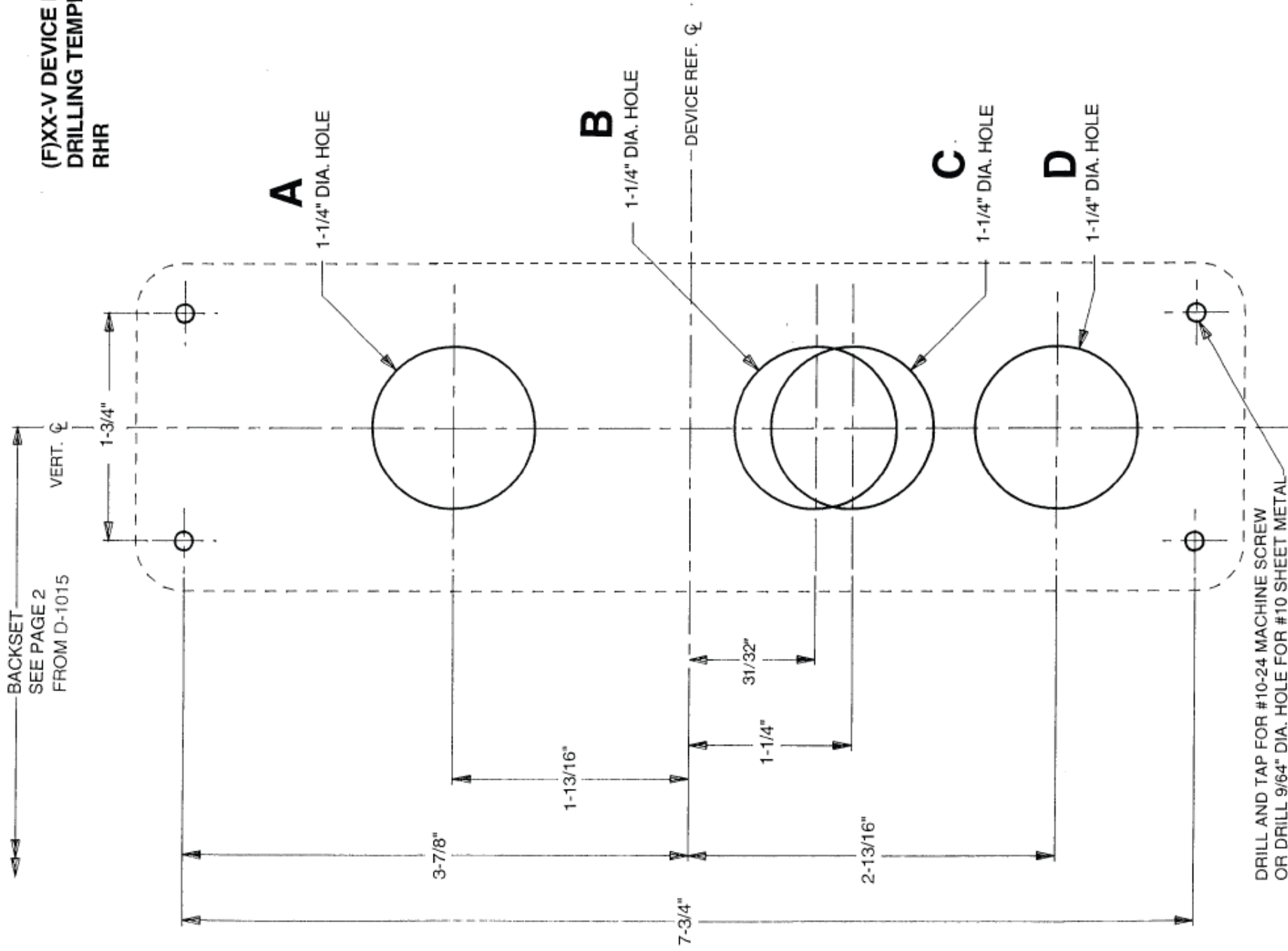

DRILL AND TAP FOR #10-24 MACHINE SCREW OR DRILL 9/64" DIA. HOLE FOR #10 SHEET METAL SCREW OR DRILL 1/4" DIA. HOLE INSIDE AND 1/2" DIA. HOLE OUTSIDE FOR THRU BOLTED TRIM OR DRILL 1/4" DIA. HOLE INSIDE AND 3/8" DIA. HOLE OUTSIDE FOR SEXBOLT (4 HOLES)

DRILL 9/64" DIA. FOR SHEET METAL SCREWS OR DRILL AND TAP #10-24 FOR MACHINE SCREWS (2 HOLES)

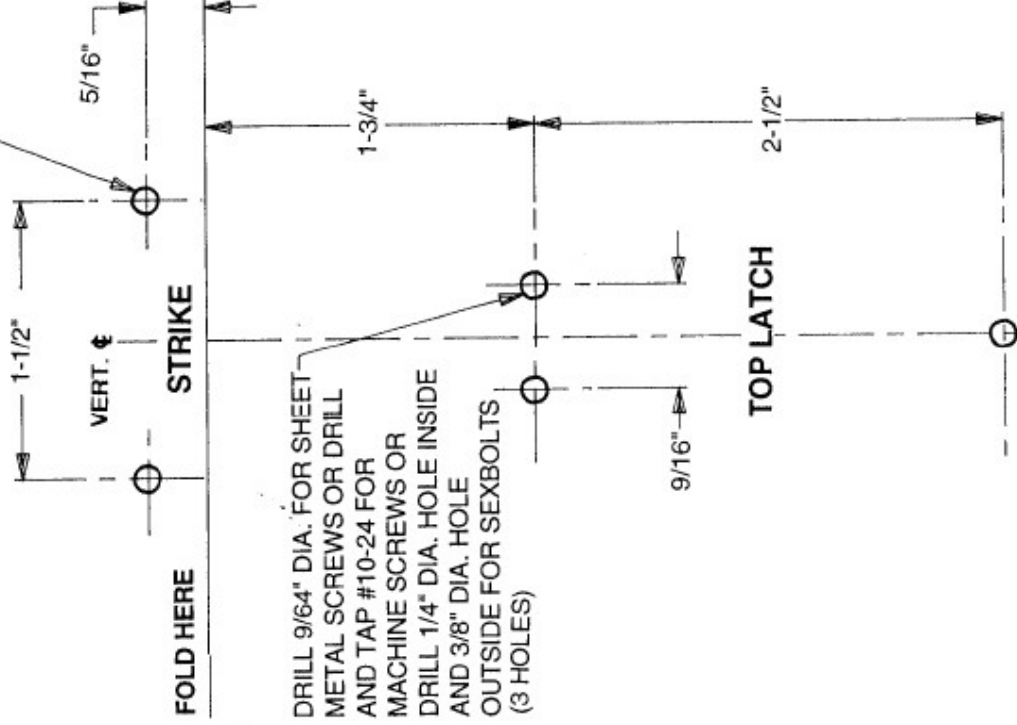

FOLD HERE

STRIKE

DRILL 9/64" DIA. FOR SHEET METAL SCREWS OR DRILL AND TAP #10-24 FOR MACHINE SCREWS OR DRILL 1/4" DIA. HOLE INSIDE AND 3/8" DIA. HOLE OUTSIDE FOR SEXBOLTS (3 HOLES)

TOP LATCH

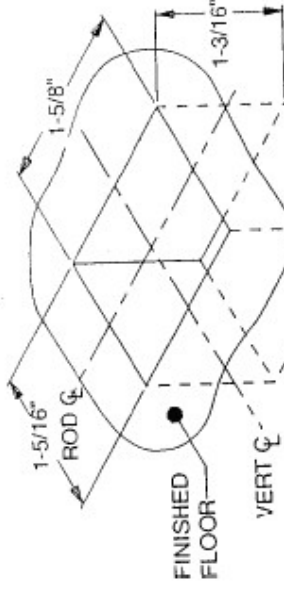

CAVITY PREPARATION FOR
2130 STRIKE

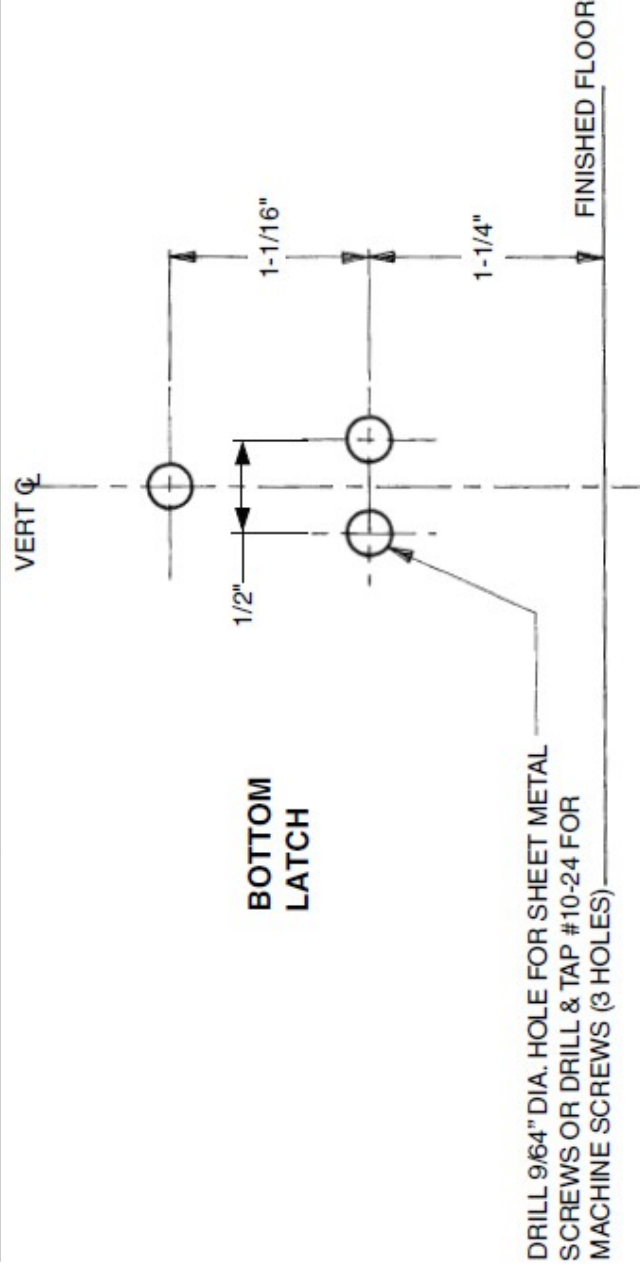

BOTTOM
LATCH

DRILL 9/64" DIA. HOLE FOR SHEET METAL SCREWS OR DRILL & TAP #10-24 FOR MACHINE SCREWS (3 HOLES)

FINISHED FLOOR