



**Trademark
HARDWARE**

www.tmhardware.com

sales@tmhardware.com

90

GLYNN-JOHNSON

Installation Instructions

**These instructions cover the following models:
90H (Hold Open), 90S (Stop only), 90F (Friction), and 90SE (Special Stop Only)**



INSTALLATION NOTES

1. Hollow metal frames should be properly reinforced with a 3/16" (5mm) minimum thickness by 12" (305mm) minimum length plate.
2. Hollow metal doors should be properly reinforced with a 3/16" (5mm) minimum thickness by 2-1/2" (64mm) minimum width plate.
3. Stop only units are permitted on many fire door applications. However, mechanical hold-open devices that require manual release are not permitted for use on any fire door as outlined on NFPA80® or NFPA101®. Contact Glynn Johnson or your local representative for assistance.

ADJUSTMENTS

Hold-open tension adjustment (Hold-open model only): Using a phillips screwdriver, turn screw shown clockwise to increase hold-open tension and counterclockwise to decrease hold open tension.

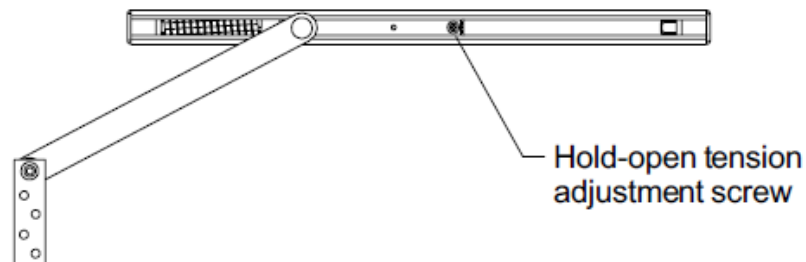

Friction adjustment (Friction model only): Using a 3/32" hex wrench, turn screw shown clockwise to increase friction and counterclockwise to decrease friction.

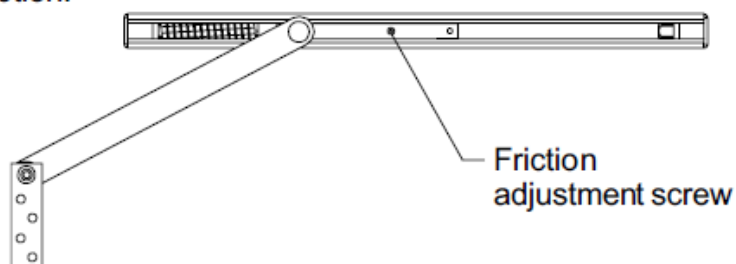

INST.90



Customer Service

1-877-671-7011 www.allegion.com



© Allegion 2015
Printed in U.S.A.
INST.90 Rev. 06/15-d



INSTALLATION STEPS

1 Determine what type of hinge or pivot is being used on the door as shown below.

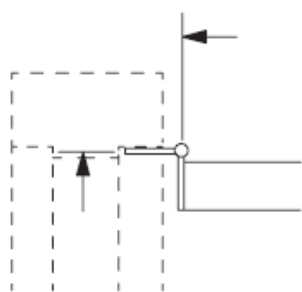

Butt Hinge

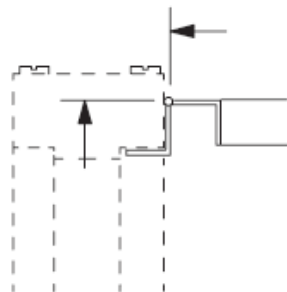

Swing Clear
Hinge

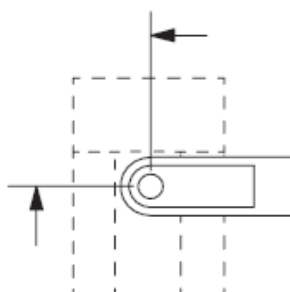

Center Hung
Pivot

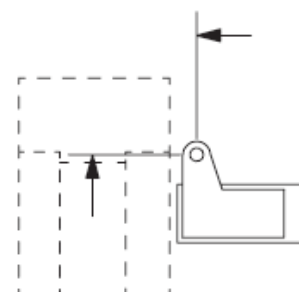

Offset Pivot

2 Find correct type and size of hinge or pivot on the chart below to identify correct mounting group.

Hinge Type & Size	Mounting Group
Butt Hinge 4" Wide	3
Butt Hinge 4-1/2" Wide	2
Butt Hinge 5" Wide	1
Swing Clear Hinge 4" Wide	1
Swing Clear Hinge 4-1/2" Wide (1-3/4" door)	3
Swing Clear Hinge 4-1/2" Wide (2" door)	2
Swing Clear Hinge 4-1/2" Wide (2-1/4" door)	1
Swing Clear Hinge 5" Wide (1-3/4" door)	3
Swing Clear Hinge 5" Wide (2" door)	2
Swing Clear Hinge 5" Wide (2-1/4" door)	1
Center Hung Pivot (1-3/4" - 2-1/4" doors)	4
3/4" Offset Pivot (1-3/8" door)	3
3/4" Offset Pivot (1-3/4" door)	2
3/4" Offset Pivot (2" or 2-1/4" door)	1
SOSS 220 (2" or 2-1/4" door)	2

3 Dimensions A, B, and C (shown below) will be used to locate holder on door and frame.

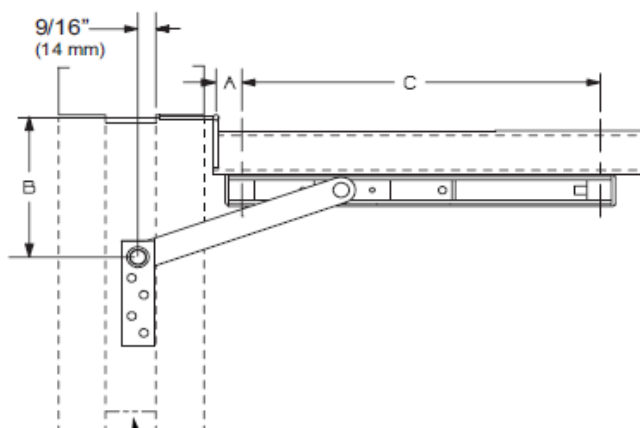

4 Using the mounting group and GJ model numbers, find dimensions "A", "B", and "C" on page 3 chart.

Notes on using chart:

- "Degrees" shown on chart represent desired hold-open degree (on hold-open, friction, and stop only models) or stop degree (on SE models).
- "l" = Arm length from center to center (for reference only).
- On hold-open, friction, and stop only models, the dead stop (DS) degree is normally 5-7 degrees beyond the hold-open degree shown on chart. The DS door position is reached when the shock spring is fully compressed.
- When installing on doors which open back-to-back, or against a wall or obstruction, it may be desirable to install the holder based on the dead stop angle rather than the hold-open angle. To do this, add 13/16" (21mm) to the "A" dimension on chart. This will effectively reduce the dead stop and hold-open by 5-7 degrees. This can only be done on hold-open, friction, and stop only models, but NOT on SE models.



**Trademark
HARDWARE**

www.tmhardware.com

sales@tmhardware.com

CAUTION: "A" & "B" dimensions are measured from the centerline of hinge, not edge of door.

GJ MODEL	DIM.	DOOR OPENING	85 degrees		90 degrees		95 degrees		100 degrees		105 degrees		110 degrees		C	I
			A	B	A	B	A	B	A	B	A	B	A	B		
902	IN.	23 1/16-27*	1 11/16*	4 5/8*	-	-	-	-	-	-	-	-	-	-	19 3/4	10
	mm	585-687	43	117	-	-	-	-	-	-	-	-	-	-	502	254
903	IN.	27 1/16-33	3 1/2	6 11/16	3 1/16*	6 1/4*	2 11/16*	5 7/8*	2 3/8*	5 9/16*	-	-	-	-	22	12
	mm	688-838	89	170	78	159	68	149	60	141	-	-	-	-	559	305
904	IN.	33 1/16-39	7	8 3/16	6 9/16	7 11/16	6 1/8	7 5/16	5 3/4	6 15/16	5 3/8	6 9/16	-	-	23 3/4	15 3/4
	mm	839-991	178	208	167	195	156	186	146	176	137	167	-	-	603	400
905	IN.	39 1/16-45	11 5/16	9	10 3/4	8 7/16	10 1/4	7 15/16	9 13/16	7 1/2	9 1/2	7 3/16	9 1/8	6 13/16	24 1/2	20
	mm	992-1143	287	229	273	214	260	202	249	191	241	183	232	173	622	508
906	IN.	45 1/16-54	17 1/4	10 7/16	16 5/8	9 3/4	16	9 3/16	15 1/2	8 11/16	15 1/8	8 1/4	14 3/4	7 15/16	26	26
	mm	1144-1372	438	265	422	248	406	233	394	221	384	210	375	202	680	660
902	IN.	23 1/16-27*	1 15/16*	4 7/8*	1 5/8*	4 9/16*	-	-	-	-	-	-	-	-	19 3/4	10
	mm	585-687	49	124	41	116	-	-	-	-	-	-	-	-	502	254
903	IN.	27 1/16-33	3 5/8	6 13/16	3 1/4*	6 7/16*	2 7/8*	6 1/16*	2 9/16*	5 3/4*	2 5/16*	5 1/2*	-	-	22	12
	mm	688-838	92	173	83	164	73	154	65	146	59	140	-	-	559	305
904	IN.	33 1/16-39	7 3/16	8 3/8	6 11/16	7 7/8	6 5/16	7 1/2	5 15/16	7 1/8	5 9/16	6 3/4	5 5/16	6 1/2	23 3/4	15 3/4
	mm	839-991	183	213	170	200	160	191	151	181	141	171	135	165	603	400
905	IN.	39 1/16-45	11 1/2	9 1/8	10 15/16	8 5/8	10 7/16	8 1/16	10	7 11/16	9 5/8	7 5/16	9 5/16	7	24 1/2	20
	mm	992-1143	292	232	278	219	265	205	254	195	244	186	237	178	622	508
906	IN.	45 1/16-54	17 7/16	10 5/8	16 3/4	9 15/16	16 3/16	9 3/8	15 11/16	8 7/8	15 1/4	8 3/8	14 7/8	8 1/16	26	26
	mm	1144-1372	443	270	425	252	411	238	398	225	387	213	378	205	680	660
902	IN.	23 1/16-27*	2 1/8	5 1/16	1 13/16	4 3/4	1 9/16	4 1/2	-	-	-	-	-	-	19 3/4	10
	mm	585-687	54	129	46	121	40	114	-	-	-	-	-	-	502	254
903	IN.	27 1/16-33	3 13/16	7	3 3/8	6 9/16	3 1/16*	6 1/4*	2 3/4*	5 15/16*	2 1/2*	5 11/16*	-	-	22	12
	mm	688-838	97	178	86	167	78	159	70	151	64	144	-	-	559	305
904	IN.	33 1/16-39	7 3/8	8 9/16	6 7/8	8 1/16	6 7/16	7 5/8	6 1/16	7 1/4	5 3/4	6 15/16	5 7/16	6 5/8	23 3/4	15 3/4
	mm	839-991	187	217	175	205	164	194	154	184	146	176	138	168	603	400
905	IN.	39 1/16-45	11 5/8	9 5/16	11 1/16	8 3/4	10 5/8	8 1/4	10 3/16	7 13/16	9 13/16	7 1/2	9 1/2	7 3/16	24 1/2	20
	mm	992-1143	295	237	281	222	270	210	259	198	249	191	241	183	622	508
906	IN.	45 1/16-54	17 5/8	10 13/16	16 15/16	10 1/16	16 3/8	9 1/2	15 7/8	9 1/16	15 7/16	8 9/16	15 1/16	8 1/4	26	26
	mm	1144-1372	448	275	430	256	416	241	403	230	392	217	383	210	680	660
902	IN.	27 1/16-33	2 13/16	5 3/4	2 1/2	5 7/16	2 3/16	5 1/8	2	4 15/16	1 3/4	4 11/16	1 9/16	4 1/2	19 3/4	10
	mm	688-838	71	146	64	138	56	130	51	125	44	119	40	114	502	254
903	IN.	33 1/16-39	4 5/16	7 7/16	3 15/16	7 1/8	3 9/16	6 3/4	3 1/4	6 7/16	3	6 3/16	2 3/4	5 15/16	22	12
	mm	839-991	110	189	100	181	90	171	83	164	76	157	70	151	559	305
904	IN.	39 1/16-45	7 7/8	9	7 3/8	8 9/16	6 15/16	8 1/8	6 9/16	7 3/4	6 1/4	7 7/16	6	7 1/8	23 3/4	15 3/4
	mm	992-1143	200	229	187	217	176	206	167	197	159	189	152	181	603	400
905	IN.	45 1/16-51	12 1/4	9 15/16	11 11/16	9 3/8	11 3/16	8 7/8	10 3/4	8 3/8	10 3/8	8	10 1/16	7 3/4	24 1/2	20
	mm	1144-1295	311	252	297	238	284	225	273	213	264	203	256	197	622	508
906	IN.	51 1/16-57	18 1/4	11 7/16	17 9/16	10 3/4	17	10 1/16	16 7/16	9 9/16	16	9 1/8	15 9/16	8 3/4	26	26
	mm	1296-1448	464	291	446	273	432	256	418	243	406	232	395	222	680	660

*Not to be used with swing clear hinges.



Trademark
HARDWARE

www.tmhardware.com

sales@tmhardware.com

5 Mark "B" dimension (from chart) on frame. Note that "B" dimension is measured from centerline of hinge as shown.

6 Cut out "Jamb Bracket Template" from bottom of page and align on frame to locate 4 holes to drill.

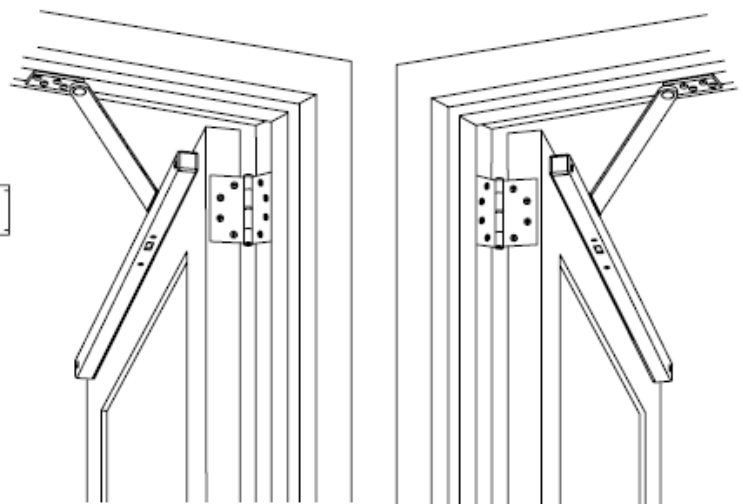
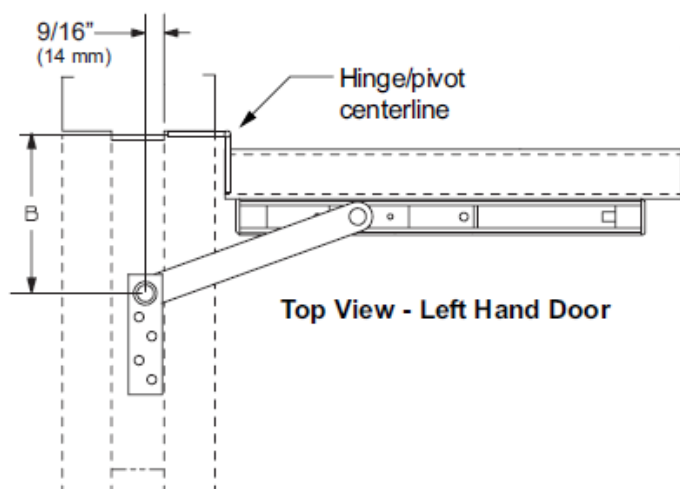

Right Hand Door

Left Hand Door

7 Locate and mark "A" and "C" dimensions on door. Note that "A" dimension is measured from centerline of hinge as shown. For dead stop add $13/16$ " (21mm) to the "A" dimension from the chart. For more information about dead stop, see page 2 under "Notes on using chart".



- 8** Drill two 3/8" (10mm) diameter through holes per chart and dimensions shown below. Mounting holes should be prepared only after door and frame are installed.

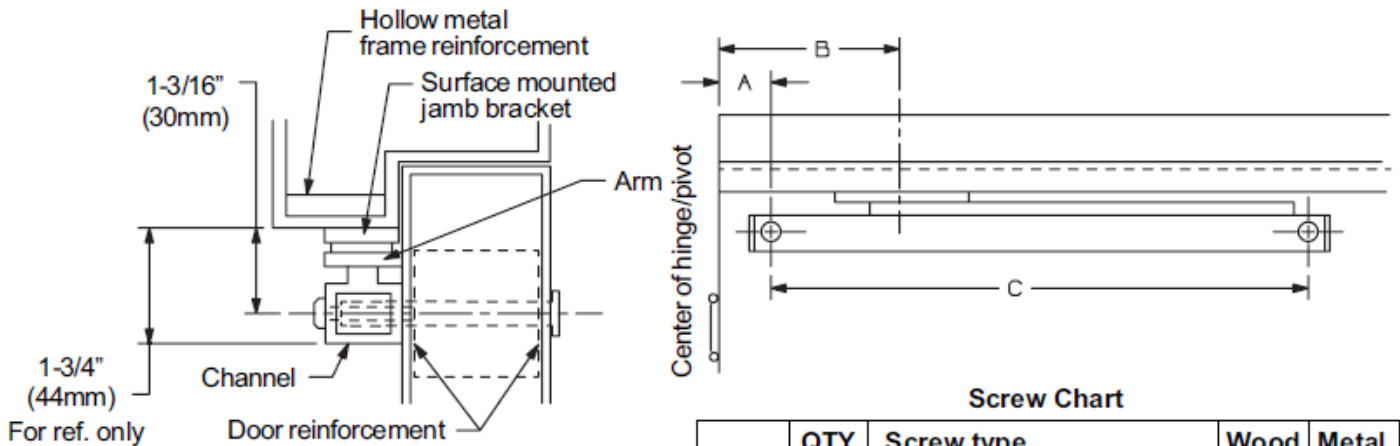

Screw Chart

	QTY	Screw type	Wood	Metal
Jamb	4	#14 x 1-1/2" FPHSMS	✓	
	4	1/4"-20 x 3/4" FPHMS		✓
Door	2	1/4"-20 x 1-1/4" OPHMS	✓	✓
	2	1/4"-20 x 2-1/2" Sex bolts	✓	✓

- 9** Install jamb bracket on the stop (see Screw Chart).
- 10** Install the channel on the door (see Screw Chart)
Shock spring should be located on hinge end of the door.

Jamb Bracket Template (actual size)

