

Assembly Instructions
Wing Line Grant® BF50 - up to 50 lbs/panel
(23 kg) for bi-fold application up to 30 lbs/
panel (14 kg) for multi-fold application, maximum 6 panels one-way

- Tools required:**
 7/16" drill bit
 Phillips head screwdriver
 1/4" wrench
 5/16" wrench
 11/16" wrench
 5/32" hex key
 1/16" hex key

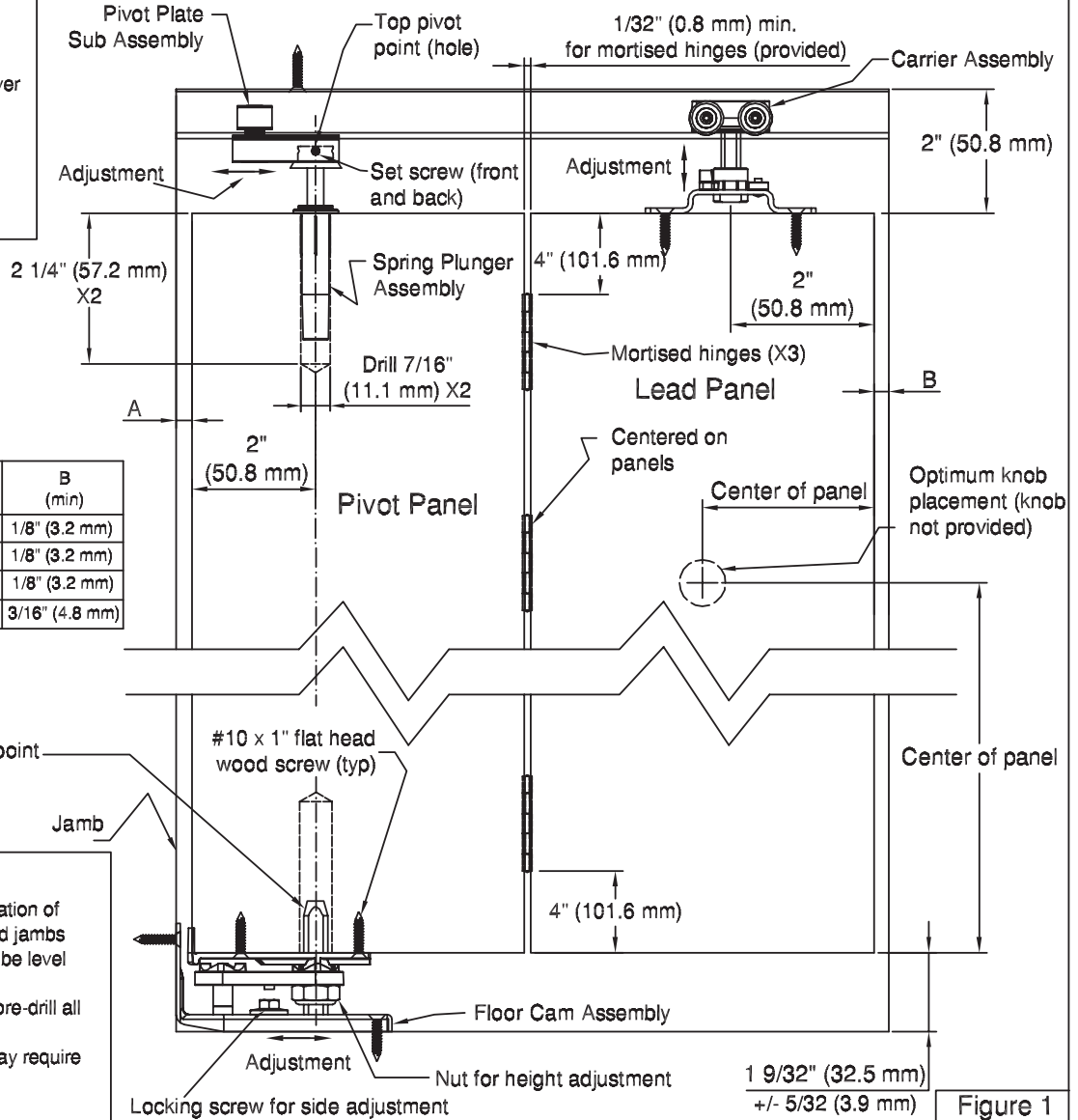

Panel thickness	A (min)	B (min)
3/4" - 7/8"	3/16" (4.8 mm)	1/8" (3.2 mm)
1" - 1 3/8"	1/4" (6.4 mm)	1/8" (3.2 mm)
1 1/2" - 1 5/8"	5/16" (7.9 mm)	1/8" (3.2 mm)
1 3/4"	3/8" (9.5 mm)	3/16" (4.8 mm)

Note:

- To assure proper operation of the system, header and jambs (door opening) should be level and square.
- It is recommended to pre-drill all screw holes.
- Warpage or settling may require future re-adjustments.

Figure 1

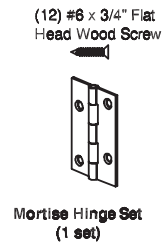
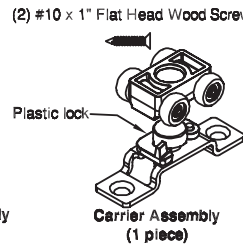
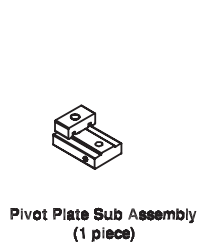
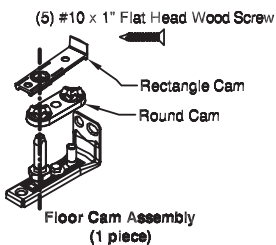

WARNING

The Grant 50 folding door hardware system is designed to support folding panels up to 50 lbs (23 kg) per panel in a bi-folding application and 30 lbs (14 kg) per panel in a multi-fold application (4 or 6 panels). The door system must be installed by attaching it to a framing member that is designed to support the total weight of door panels plus the weight of the door system ("Total Support Weight"). Improper installation of the door system, including, but not limited to, the use of unauthorized hardware, or the failure to install the door system by attaching it to a framing member that is designed to support the Total Support Weight, could result in serious injury or death. **DO NOT INSTALL THE DOOR SYSTEM TO A FRAMING MEMBER THAT IS NOT DESIGNED TO SUPPORT AT LEAST THE TOTAL SUPPORT WEIGHT. INSTALL THE DOOR SYSTEM ONLY IN THE MANNER SET FORTH IN THE DOOR SYSTEM'S DOOR HARDWARE INSTALLATION INSTRUCTIONS.**

071-11-0134-00-0, Rev. D [INSTRUC/071-11-0134-00-0]

Assembly Instructions, Wing Line Grant® BF50

1. Prepare pivot panel (first panel)

Drill top and bottom pivot holes in pivot panel on centerline (per Fig. 1, using the rectangle cam to mark the center of the holes). Attach rectangle cam to the bottom of the panel on centerline.

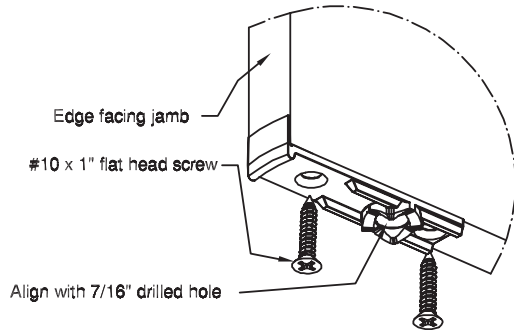

2. Prepare lead panel (second panel)

Mount the top plate of the carrier assembly on panel centerline (per Fig. 1). (Note the orientation of the top plate opening to the leading edge.)

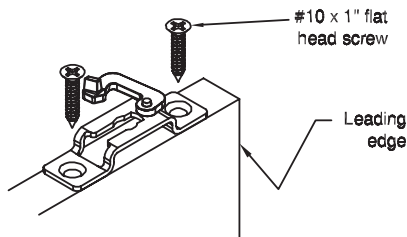

3. Hinge panels

Hinge pivot and lead panel together using #6 x 3/4 inch flat head screws. Space hinges per Fig. 1.

Note (for multi-fold installation):

- Mark hinge screw locations between panels 2 and 3.
- Follow instructions for bi-fold installation (panels 1 and 2).
- After adjustments for bi-fold installation, mount carrier(s) to panel 4 (and panel 6 if required), bring into position, and install hinge screws between panels 2 and 3.

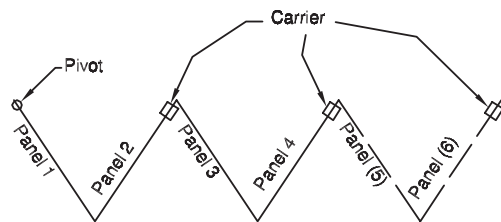

4. Install track

4A) Insert

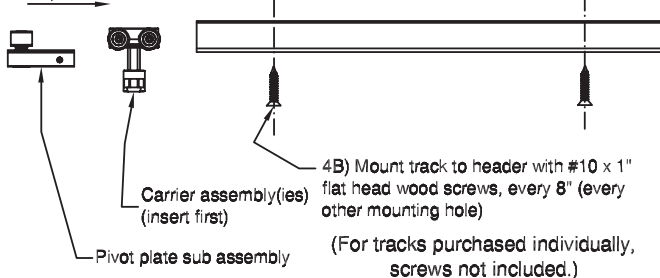

5. Install hardware

- Position top pivot point hole of pivot plate sub assembly at the correct dimension from the jamb (per Fig. 1) and secure using 5/32 inch hex key.
- Adjust lower pivot point of floor cam assembly to correct dimension from the jamb (per Fig. 1). Making sure the top pivot point and lower pivot point are plumb, mount floor cam assembly using (3) #10 x 1 inch flat head screws.

6. Orientation of round cam for "stay open / stay close" mechanism

Orient the round cam and rectangle cam as shown for the correct swing.

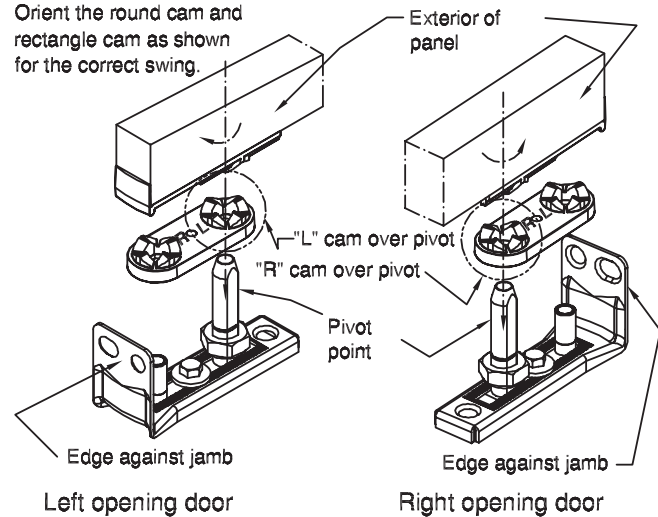

7. Install panels

- Install spring plunger into top (drilled) hole of pivot panel.
- Place hole in bottom of pivot panel over the floor cam stud.
- Place spring plunger into the top pivot plate hole and adjust door height to be sure spring plunger is seated correctly as shown below.

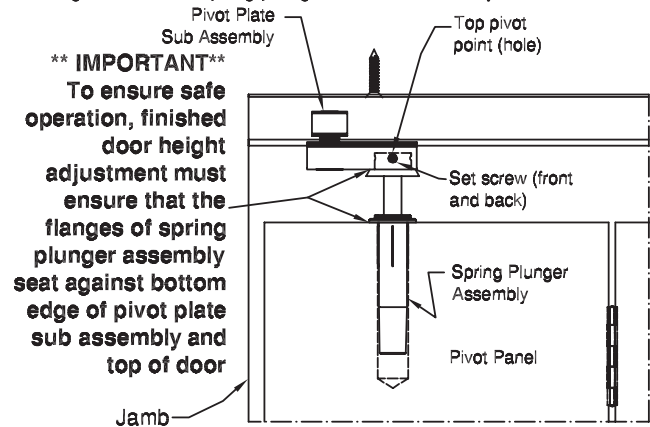

**** IMPORTANT ****
To ensure safe operation, finished door height adjustment must ensure that the flanges of spring plunger assembly seat against bottom edge of pivot plate sub assembly and top of door

- Secure spring plunger assembly with (2) set screws using a 1/16 inch hex key (set screws should "dig into" the plastic end of the spring plunger assembly to secure).
- (Make sure locking screw for side adjustment of floor cam assembly is not tight at this point.)
- Install carrier housing into top plate and lock in with plastic lock. (Lock must be open for adjustment.)
- Adjust panels to optimize operation via pendant bolt of carrier assembly, adjustment nut of floor cam assembly, and side adjustment of floor cam assembly. After adjustments are made, tighten locking screw for side adjustment of floor cam assembly.
- Mount door knob as shown on lead panel. (For multi-fold installations mount knob on each panel attached to a carrier.)

Toutes les instructions en français et espagnol sont disponibles sur nos sites Internet: www.grantdoorhardware.com ou www.hettichamerica.com

Para ver las traducciones al español o al francés de estas instrucciones, visite nuestro sitio web www.grantdoorhardware.com o www.hettichamerica.com