



Sliding door system for universal
cabinet constructions: **TopLine M**

Technik für Möbel

Hettich

Slide it. Love it.

Everyone does it: Slide it. Love it.

People like to keep it simple. On their tablet PCs. On their smartphones. The revolutionary aesthetic appeal of virtual sliding fascinates millions: gentle, flowing movement, simply at the touch of a finger. But sliding in the real world's right on trend too. Truly practical cars have a sliding door; a sliding roof provides fresh air and a feeling of freedom, and at home we slide panel curtains and doors as room dividers or on furniture.

Are you open to new trends? Because if you are, new doors are about to open for you too. In this case they open to the side. Whether for the bedroom, living room or kitchen furniture – Hettich gives you innovative sliding door systems that go perfectly with your furniture.



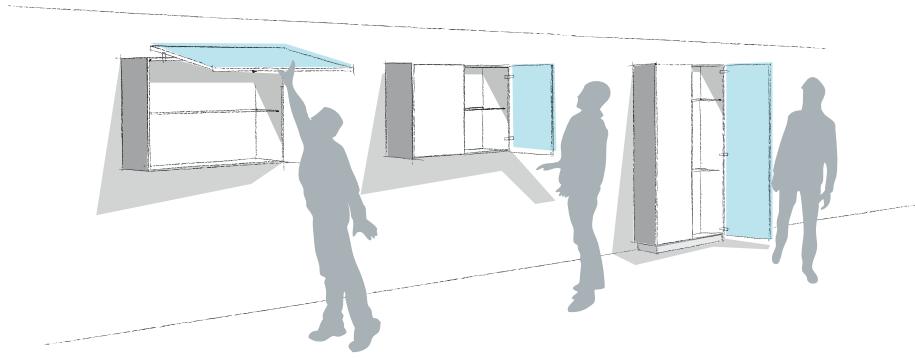

Ergonomics

Benefits that come with sliding doors

Sliding doors show what they're made of in everyday use. In terms of ergonomics and convenience, most consumers think sliding doors are better. And for good reason: open sliding doors don't get in the way where space is at a premium.

Open doors on wall units are not likely to leave you injured. Sliding doors are also easy to open without stretching or dodging out the way.

Design

Being creative with sliding doors

Sliding doors provide the key to picking up on modern, spacious interior design and continuing it in furniture. Large surface doors open the way to purist interior design.

Modern sliding door systems create a look that impresses with narrow reveals that can also be kept to a minimum with large surface fronts. Easy precision adjustment provides superb finished results with perfect gap alignment.

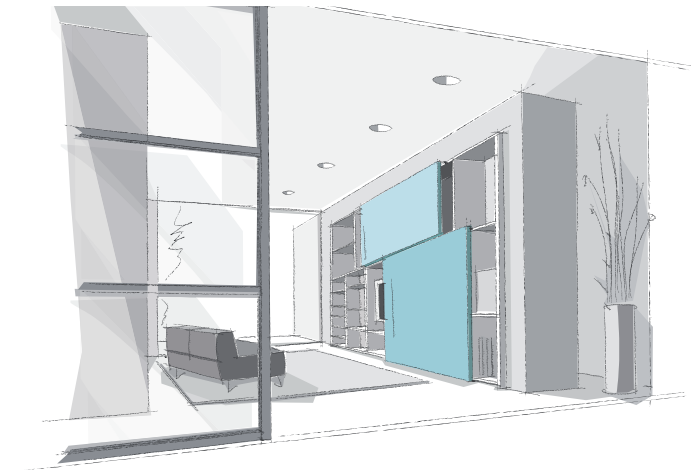

Functionality

What good cabinet doors need to do

When it comes to cabinet doors, it's the practical aspects most consumers attach importance to, particularly to ease of opening and closing. The benefit of linear movement provided with sliding doors should be combined with minimum effort needed to open them. Also appreciated is the convenience of Silent System for soft, gentle and silent closing.

The perfect sliding door system is also expected to come with outstanding running performance and offer quality you can rely on.

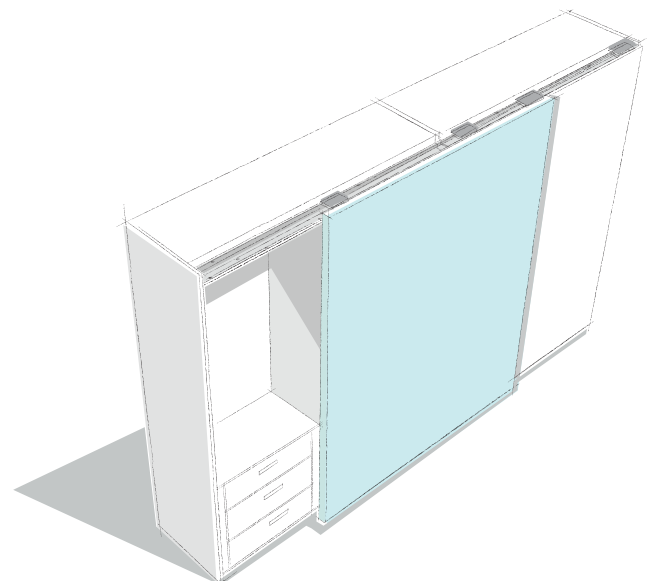

Sliding door system / top running

- ▶ TopLine M / overlay door position
- ▶ All the benefits at a glance



Great look for small formats. The TopLine M sliding door system lets you bring great design format to small sized cabinets – with door weights up to 35 kg. TopLine M also

fits on standardized cabinets originally designed for overlay hinged doors. This makes it ideal for converting existing cabinets – from hinged doors to space saving sliding doors.



Smooth and quiet: Silent System lets doors close quietly and gently.



Quickly transformed: from hinged door to sliding door – without structural modifications.



Ready for wide: fully overlapping doors for wide internal drawers.



Free to choose: the bottom profile can also be mounted below or in front of the bottom panel.

Sliding door system / top running

- ▶ TopLine M / overlay door position
- ▶ Summary

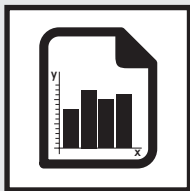

Performance summary

- ▶ Technical details in brief 4
- ▶ Door sizes 4
- ▶ Silent System 4
- ▶ Operating principle 5

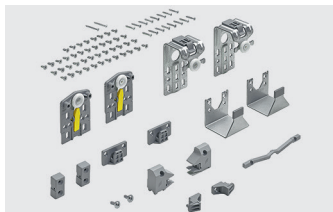

System components

6 - 12

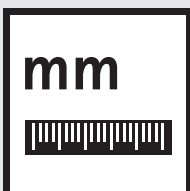

Planning dimensions

14 - 17



Installation

18 - 19



Accessories

20 - 26



Technical information

- ▶ Calculating door weights 28 - 29
- ▶ Design advice sliding door systems 30 - 32
- ▶ Quality criteria 33

Top running sliding door system



- ▶ TopLine M / overlay door position
- ▶ Performance summary

Technical details in brief

- ▶ 2-track, top running sliding door system
- ▶ Overlay door position
- ▶ For wooden doors
- ▶ Door weight up to 35 kg
- ▶ Door height up to 2300 mm
- ▶ Door width 500 - 1250 mm
- ▶ Door thicknesses 15, 16, 18, 19 mm
- ▶ 2 opening versions: fully flush or offset when using projecting handles
- ▶ Tested to EN 15706, Level 2

Door size and door weight

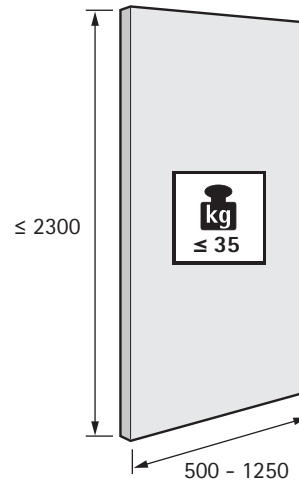

see pages 28 - 29

Door material

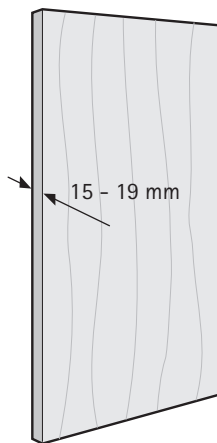

Number of door wings and door position

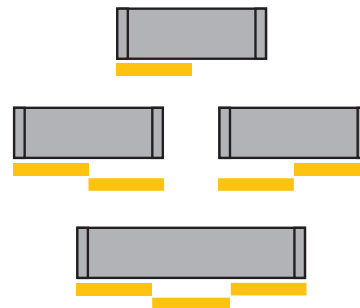

Silent System

	1-door	2-door	3-door	
Soft closing				

Top running sliding door system

- ▶ TopLine M / overlay door position
- ▶ Performance summary



Operating principle / installation dimensions

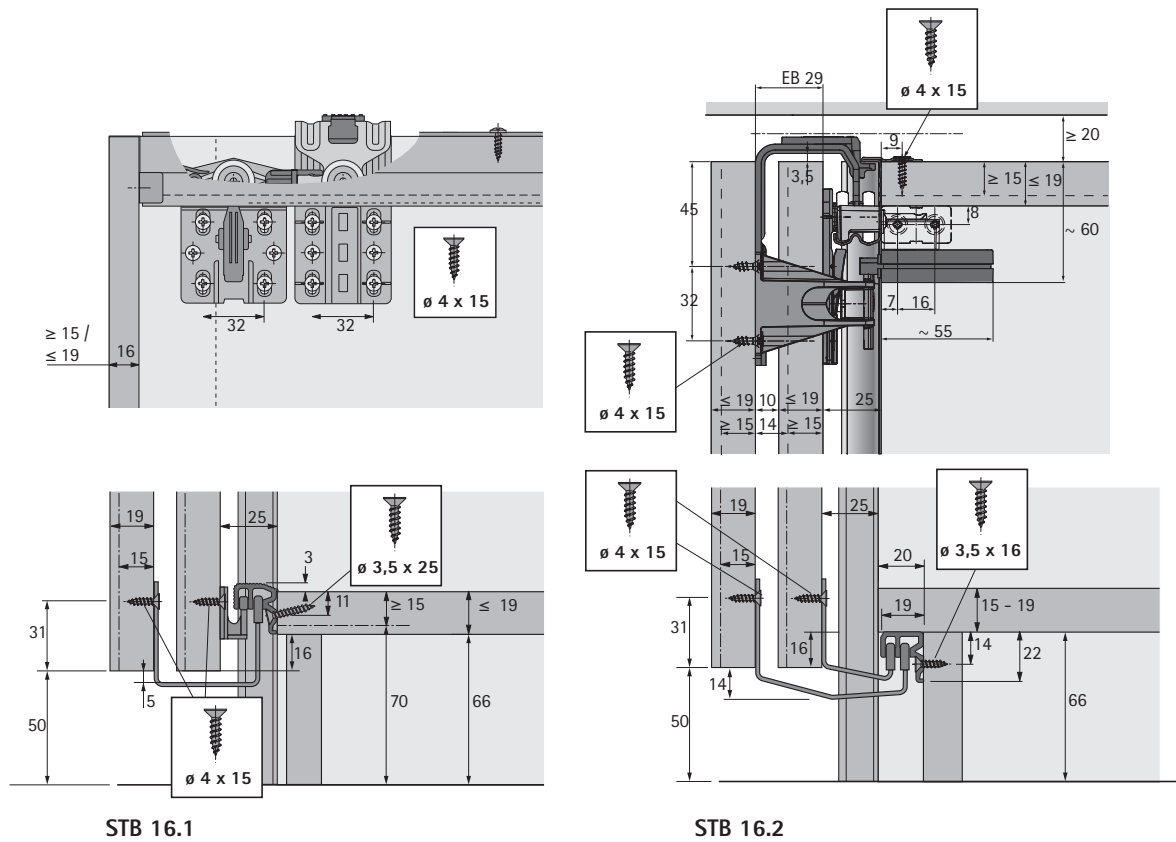

Operating principle / flush opening

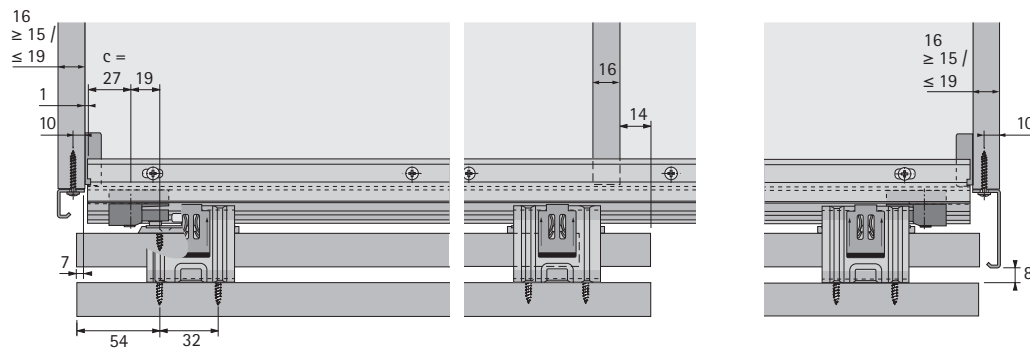

Operating principle / offset opening

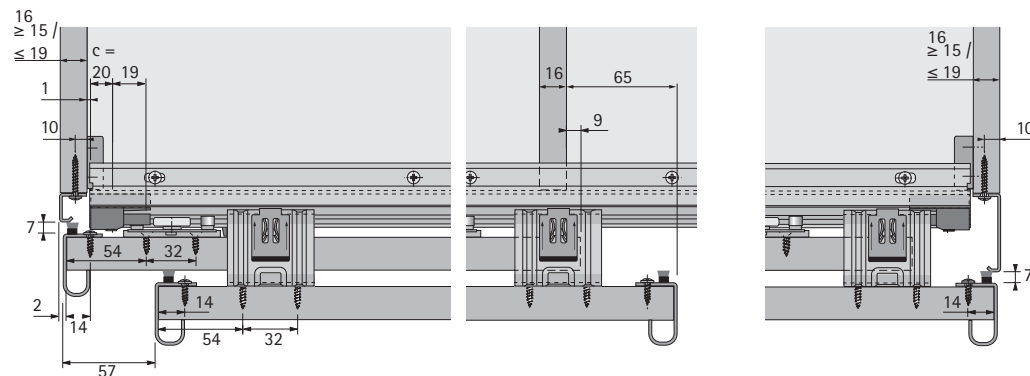

- ▶ TopLine M / overlay door position
- ▶ System components / 2-door

STB 16.1 set for runner system in front of the bottom panel

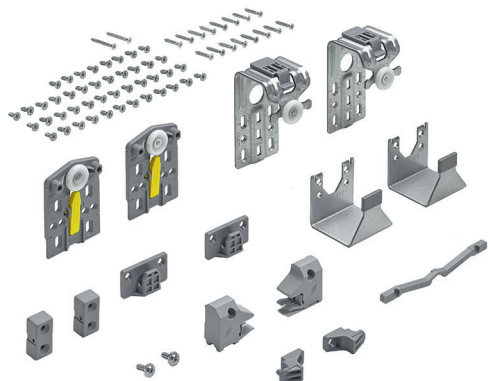
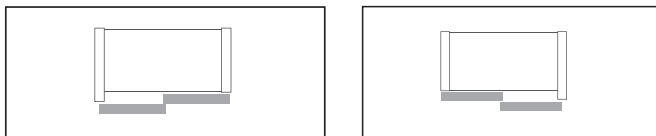

- ▶ Offset opening for applications with door handles or finger pulls (door offset: 58 mm)
- ▶ Flush opening for handleless applications and when using internal drawers (door offset: 0 mm)
- ▶ Running components with integrated lift off guard
- ▶ Package contains all the fitting parts required for an entire 2-door cabinet
- ▶ For door thicknesses of maximum 19 mm (EB 29)

Set comprises:

- ▶ 2 running components for one front most door
- ▶ 2 running components for one rear most door
- ▶ 2 guide components for one front most door
- ▶ 2 guide components for one rear most door
- ▶ 2 support blocks for the runner profile
- ▶ 2 end stops for the runner profile
- ▶ 1 spacer for offset opening
- ▶ Fixing material

Advice:

- ▶ Please order profiles separately

Version	Order no.	PU
Standard	9 133 612	1 set
For extreme climatic conditions	9 130 735	1 set

STB 16.2 set for runner system below the bottom panel

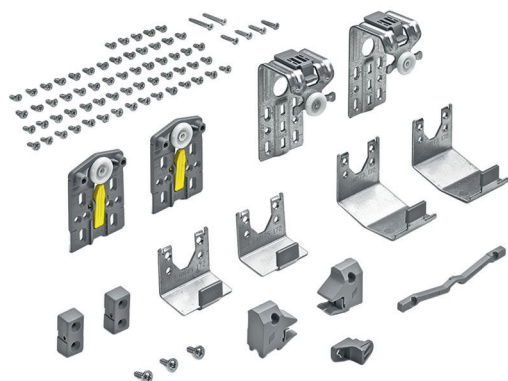
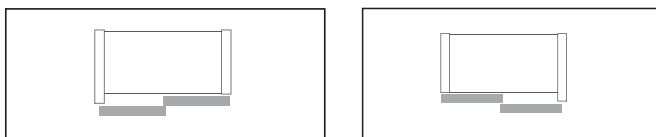

- ▶ Offset opening for applications with door handles or finger pulls (door offset: 58 mm)
- ▶ Flush opening for handleless applications and when using internal drawers (door offset: 0 mm)
- ▶ Running components with integrated lift off guard
- ▶ Package contains all the fitting parts required for an entire 2-door cabinet
- ▶ For door thicknesses of maximum 19 mm (EB 29)

Set comprises:

- ▶ 2 running components for one front most door
- ▶ 2 running components for one rear most door
- ▶ 2 guide components for one front most door
- ▶ 2 guide components for one rear most door
- ▶ 2 support blocks for the runner profile
- ▶ 2 end stops for the runner profile
- ▶ 1 spacer for offset opening
- ▶ Fixing material

Advice:

- ▶ Please order profiles separately

Version	Order no.	PU
Standard	9 133 641	1 set

- ▶ TopLine M / overlay door position
- ▶ System components / 2-door

Silent System soft closing set

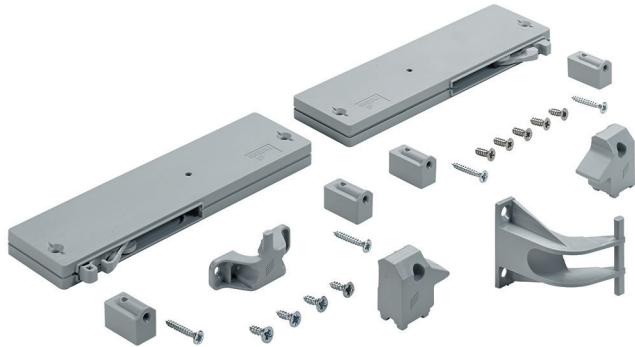
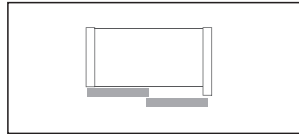
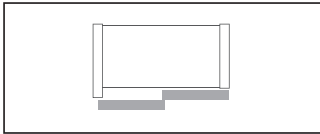

- ▶ Quietly and gently closing sliding doors
- ▶ Little effort required for easy door movement

Set comprises:

- ▶ 2 soft closing elements
- ▶ 2 activators
- ▶ 4 mounting adapters
- ▶ 2 end stops
- ▶ Fixing material

Advice:

- ▶ Please order fitting sets and profiles separately
- ▶ Soft closing element can only be used for offset opening

Order no.	PU
9 144 901	1 set

STB 16.1 set for runner system in front of the bottom panel

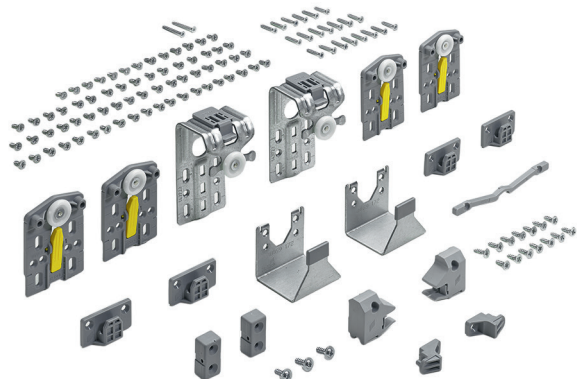
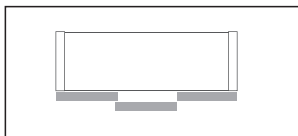

- ▶ Offset opening for applications with door handles or finger pulls (door offset: 58 mm)
- ▶ Flush opening for handleless applications and when using internal drawers (door offset: 0 mm)
- ▶ Running components with integrated lift off guard
- ▶ Package contains all the fitting components required for an entire 3-door cabinet
- ▶ For door thicknesses of maximum 19 mm (EB 29)

Set comprises:

- ▶ 2 running components for one front most door
- ▶ 4 running components for two rear most doors
- ▶ 2 guide components for one front most door
- ▶ 4 guide components for two rear most doors
- ▶ 2 support blocks for the runner profile
- ▶ 2 end stops for the runner profile
- ▶ 1 spacer for offset opening
- ▶ Fixing material

Advice:

- ▶ Please order profiles separately

Version	Order no.	PU
Standard	9 129 577	1 set
For extreme climatic conditions	9 133 586	1 set

STB 16.2 set for runner system below the bottom panel

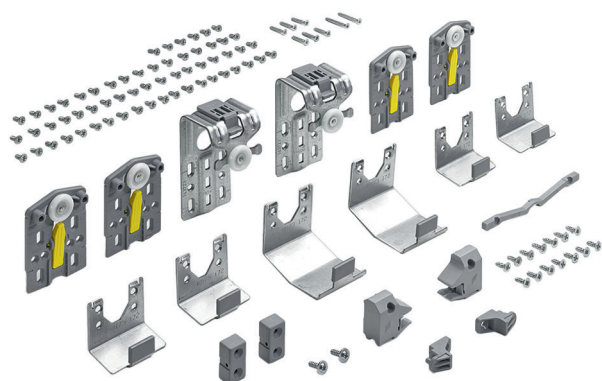
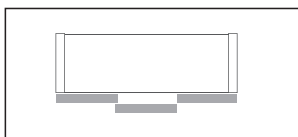

- ▶ Offset opening for applications with door handles or finger pulls (door offset: 58 mm)
- ▶ Flush opening for handleless applications and when using internal drawers (door offset: 0 mm)
- ▶ Running components with integrated lift off guard
- ▶ Package contains all the fitting components required for an entire 3-door cabinet
- ▶ For door thicknesses of maximum 19 mm (EB 29)

Set comprises:

- ▶ 2 running components for one front most door
- ▶ 4 running components for two rear most doors
- ▶ 2 guide components for one front most door
- ▶ 4 guide components for two rear most doors
- ▶ 2 support blocks for the runner profile
- ▶ 2 end stops for the runner profile
- ▶ 1 spacer for offset opening
- ▶ Fixing material

Advice:

- ▶ Please order profiles separately

Version	Order no.	PU
Standard	9 133 642	1 set

- ▶ TopLine M / overlay door position
- ▶ System components / 3-door

Silent System soft closing set

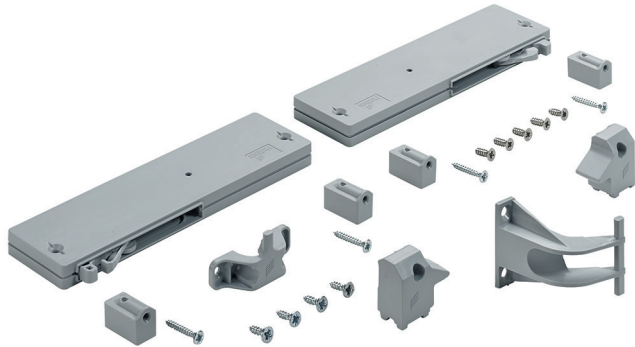

- ▶ Quietly and gently closing sliding doors
- ▶ Little effort required for easy door movement

Set comprises:

- ▶ 2 soft closing elements
- ▶ 2 activators
- ▶ 4 mounting adapters
- ▶ 2 end stops
- ▶ Fixing material

Advice:

- ▶ Please order fitting sets and profiles separately
- ▶ Soft closing element can only be used for offset opening
- ▶ 3-door: soft closing for rear most doors

Order no.	PU
9 144 902	1 set

Runner profile



▶ Standard lengths including fixing holes

Advice:

- ▶ Customized lengths on request
- ▶ Drillings for end stops and Silent System on request

Material	Finish	Length mm	Order no.	PU
steel	silver, coated	2500	9 138 054	1 ea.
steel	silver, coated	3000	9 138 055	1 ea.
aluminium	silver, anodized	2500	9 131 818	1 ea.
aluminium	silver, anodized	3000	9 131 819	1/1 ea.

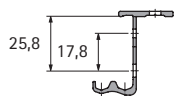
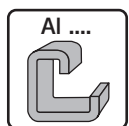
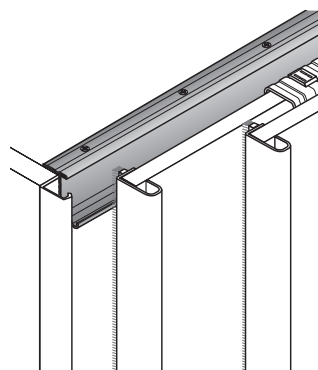

c = 34 - Door overlay

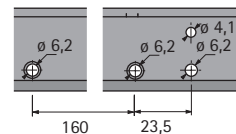
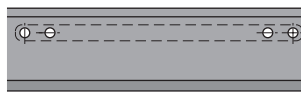
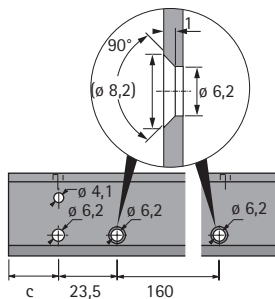

- ▶ TopLine M / overlay door position
- ▶ System components

Guide profile STB 16.1

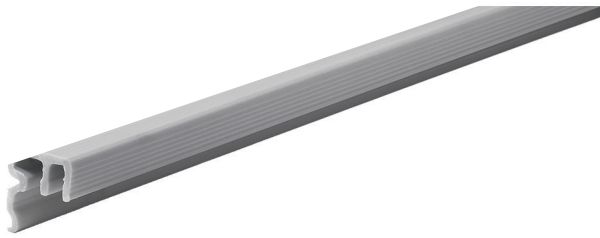

- ▶ Runner system in front of the bottom panel, STB 16.1
- ▶ Standard lengths including fixing holes
- ▶ Plastic, grey

Advice:

- ▶ Customized lengths and drillings on request

Length mm	Order no.	PU
2500	9 131 836	1 ea.
3000	9 131 837	1 ea.

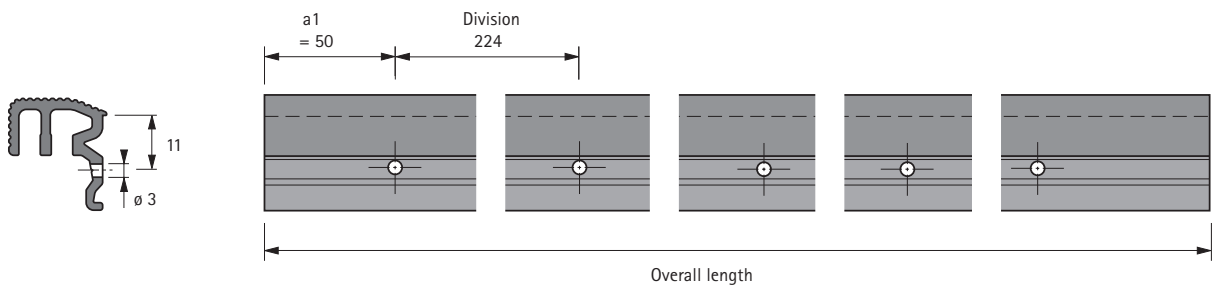

- ▶ TopLine M / overlay door position
- ▶ System components

Guide profile STB 16.2

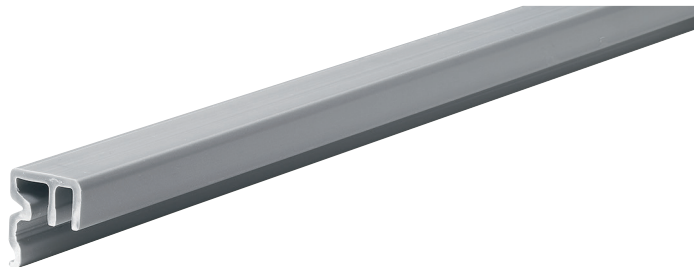

- ▶ Runner system below bottom panel STB 16.2
- ▶ Standard lengths including fixing holes
- ▶ Plastic, grey

Advice:

- ▶ Customized lengths and drillings on request

Length mm	Order no.	PU
2500	9 131 832	1 ea.
3000	9 131 833	1 ea.

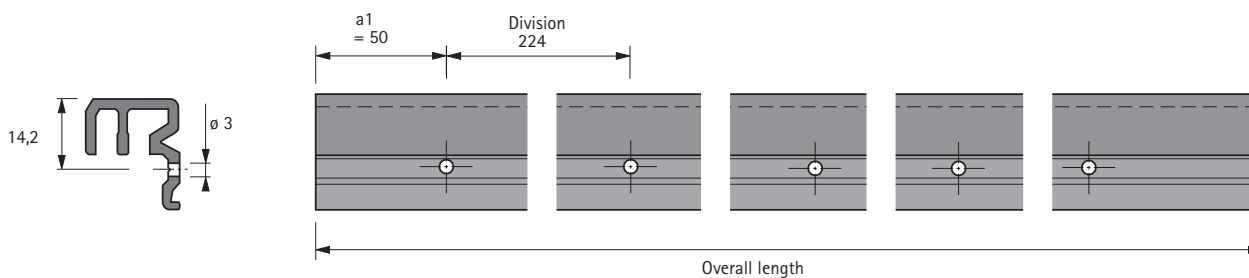

Sliding door system / top running

- ▶ TopLine M / overlay door position
- ▶ Planning dimensions

Installation dimensions / STB 16.1 runner system

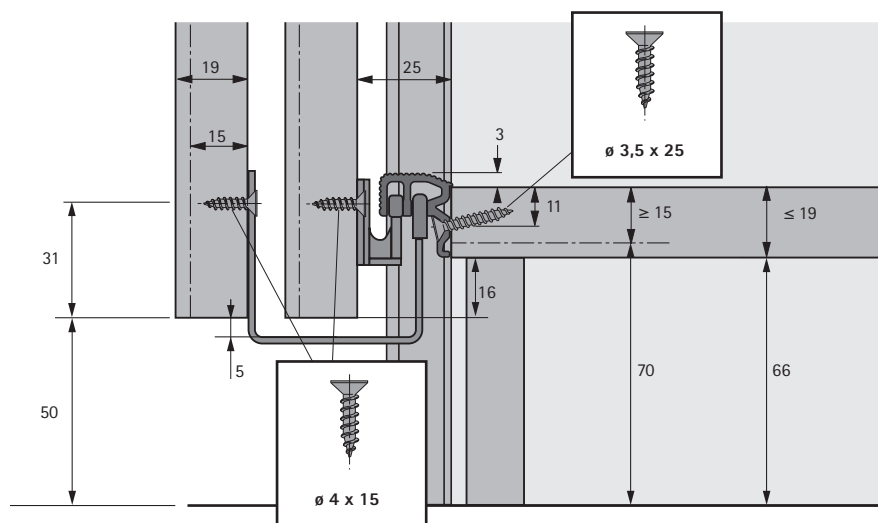
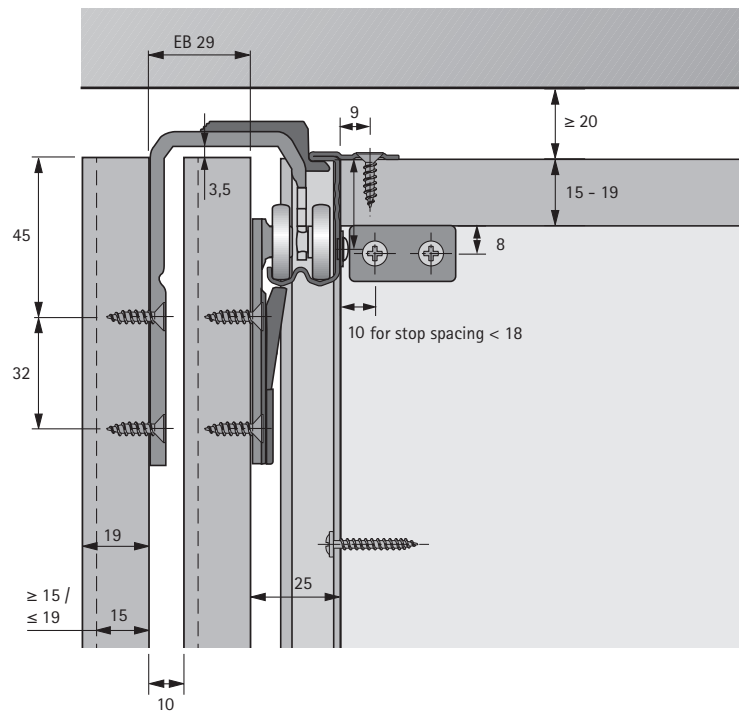

Sliding door system / top running

- ▶ TopLine M / overlay door position
- ▶ Planning dimensions

Installation dimensions / STB 16.2 runner system

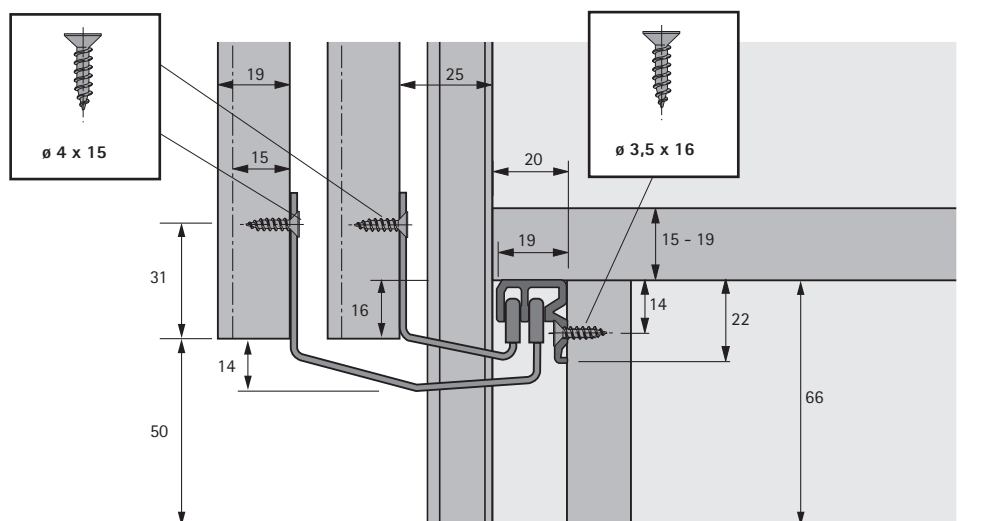
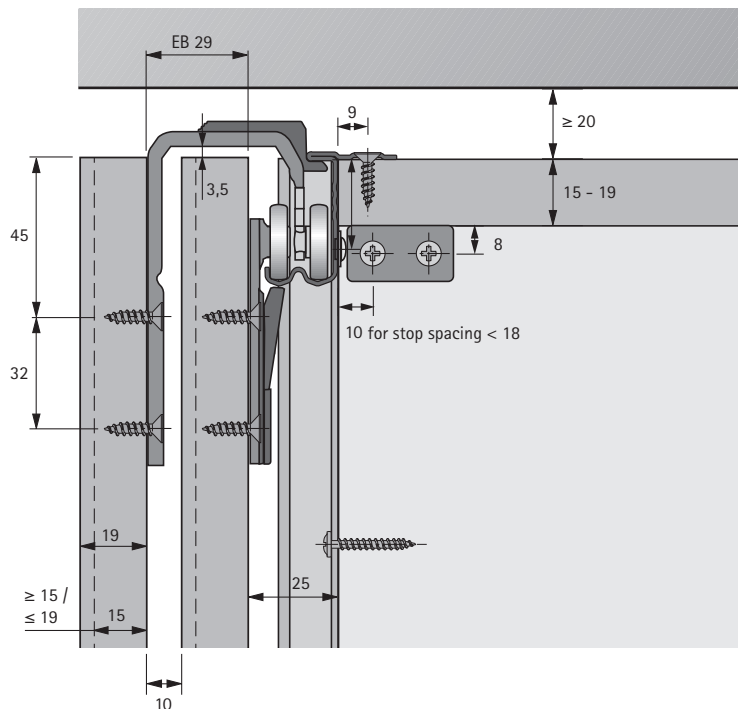

Sliding door system / top running

- ▶ TopLine M / overlay door position
- ▶ Planning dimensions

Installation dimensions for Silent System soft closing

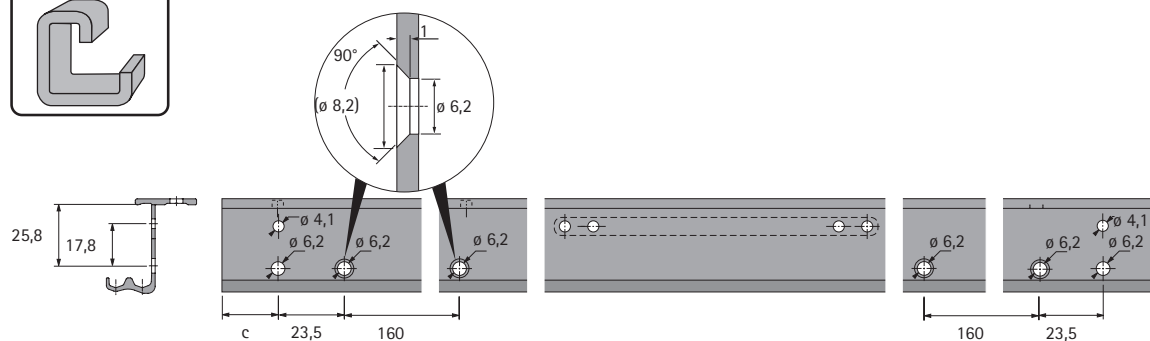
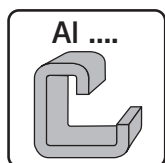
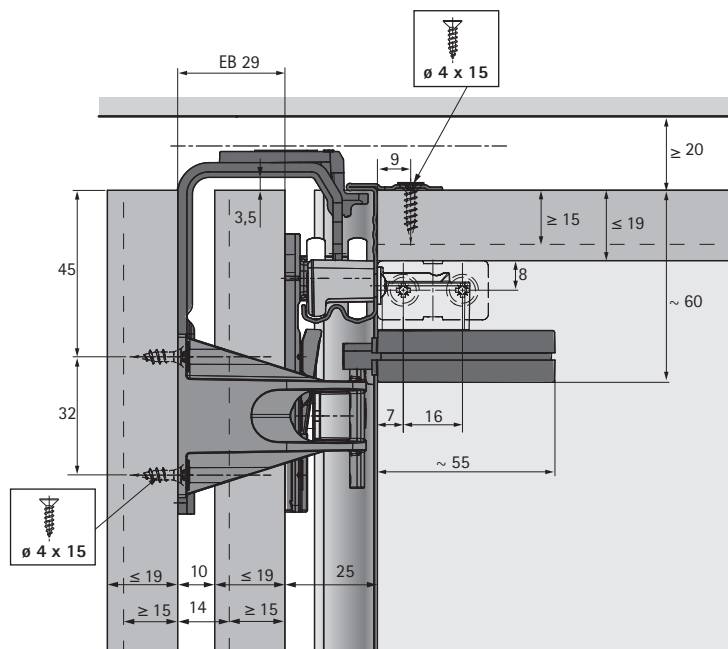

c = 34 - Door overlay

Sliding door system / top running

- ▶ TopLine M / overlay door position
- ▶ Installation

Installation in brief

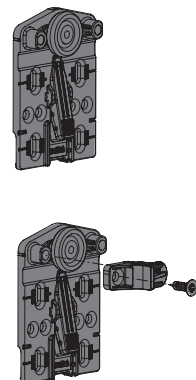
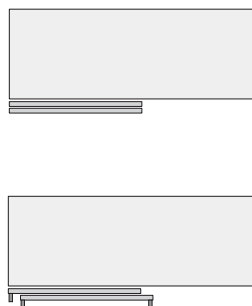
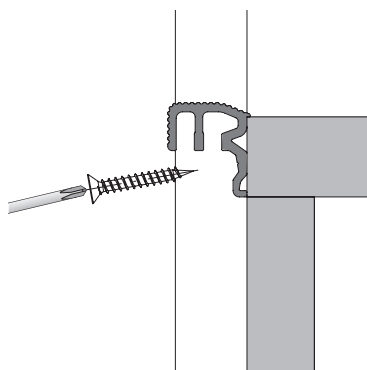
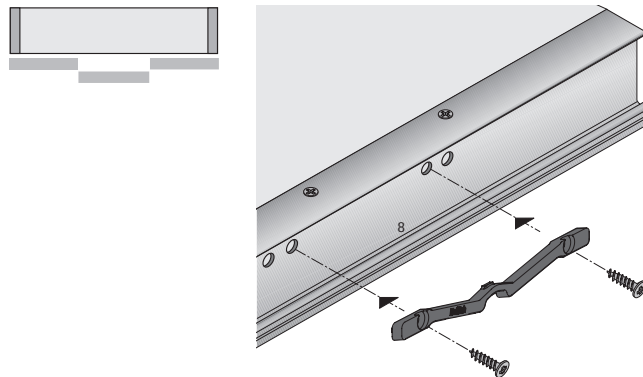
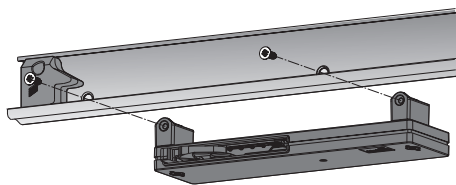
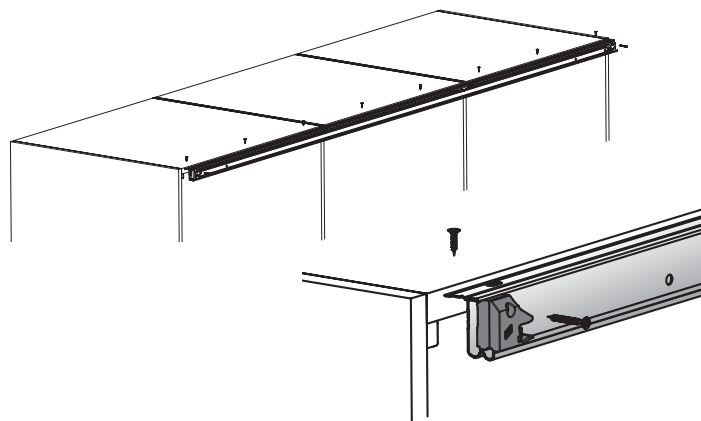
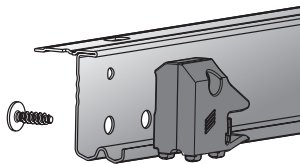
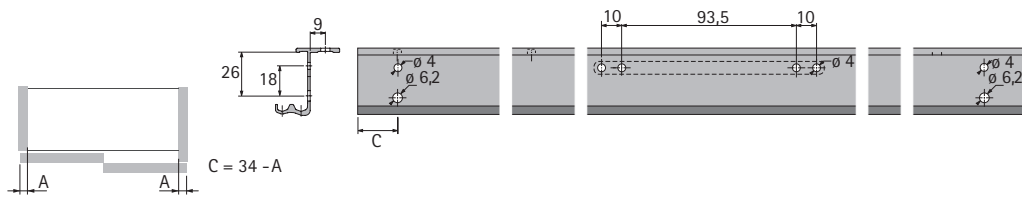

Sliding door system / top running

- ▶ TopLine M / overlay door position
- ▶ Installation

Installation in brief

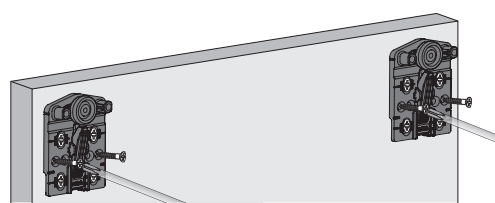
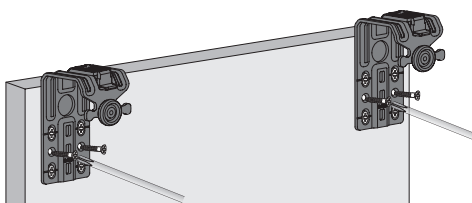
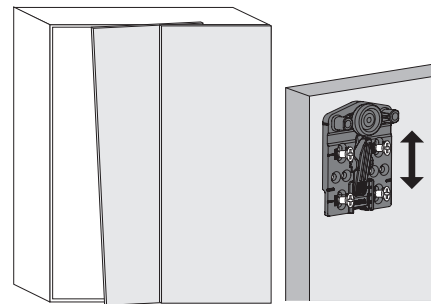
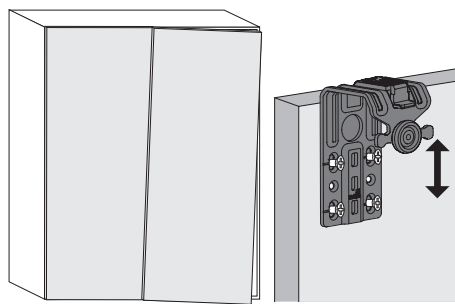
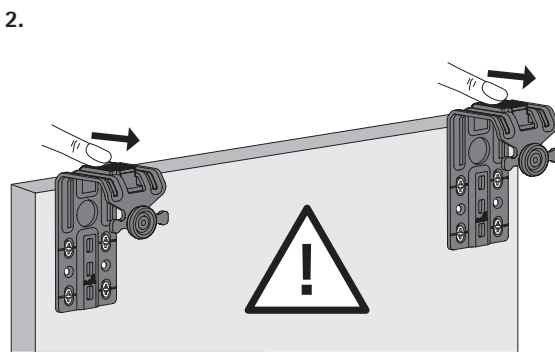
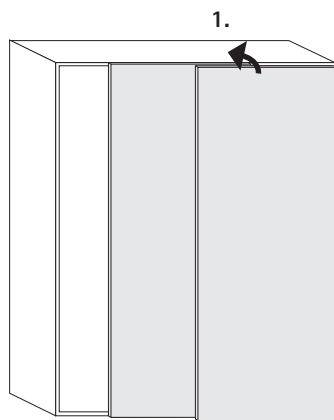
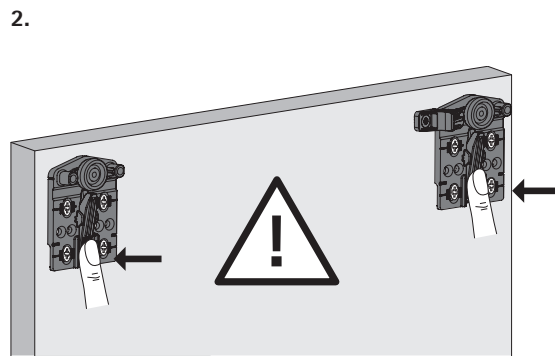
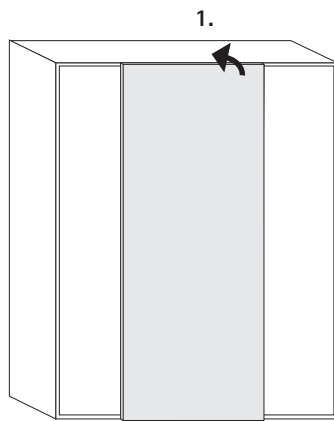

Door profile



- Predrilled
- For door thicknesses of 15 - 16 mm
- Customized lengths on request

Material	Finish	Length mm	Quantity for 2-doors	Quantity for 3-doors	Order no.	PU
steel	silver, coated	2500	3	4	9 206 249	1 ea.
Aluminium	silver, anodized	2500	3	4	9 130 038	1 ea.

Installation / dimensional drawing

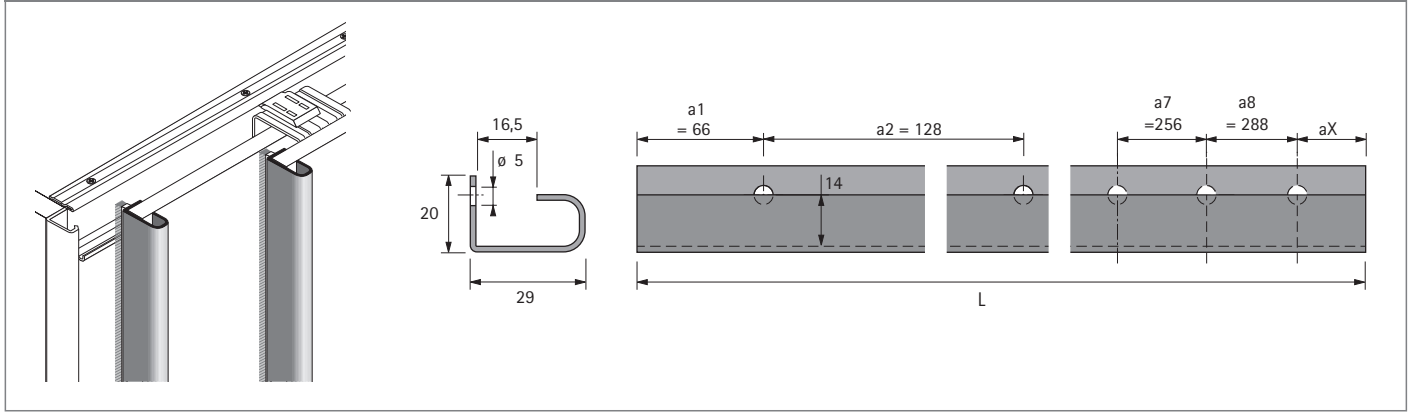

Door profile

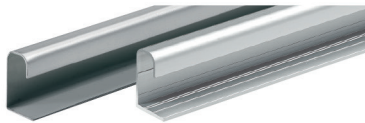

- Predrilled
- For door thicknesses of 18 - 19 mm
- Customized lengths on request

Material	Finish	Length mm	Quantity for 2-doors	Quantity for 3-doors	Order no.	PU
steel	silver, coated	2500	3	4	9 206 250	1 ea.
Aluminium	silver, anodized	2500	3	4	9 136 121	1 ea.

Installation / dimensional drawing

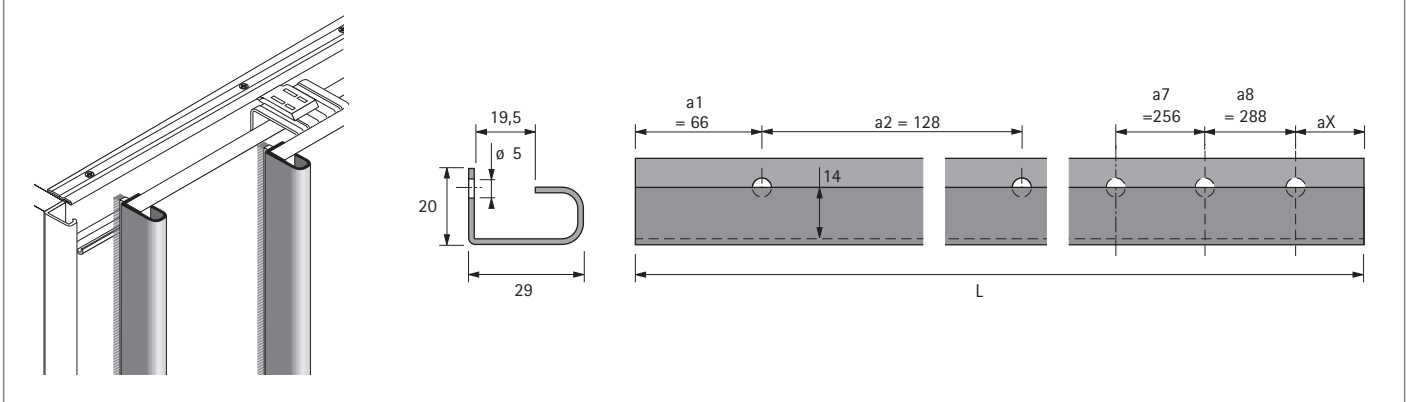

Door end profile, L shaped

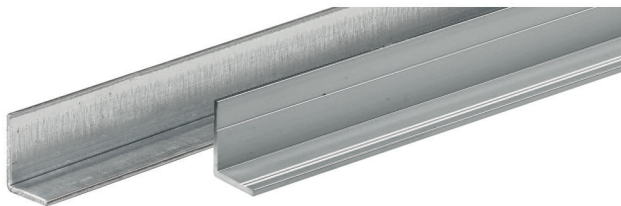

- Predrilled
- For door thicknesses of 15 - 16 mm
- Customized lengths on request

Material	Finish	Length mm	Quantity for 2-doors	Order no.	PU
steel	silver, galvanized	2500	1	9 206 307	1 ea.
Aluminium	silver, anodized	2500	1	9 136 123	1 ea.

Installation / dimensional drawing

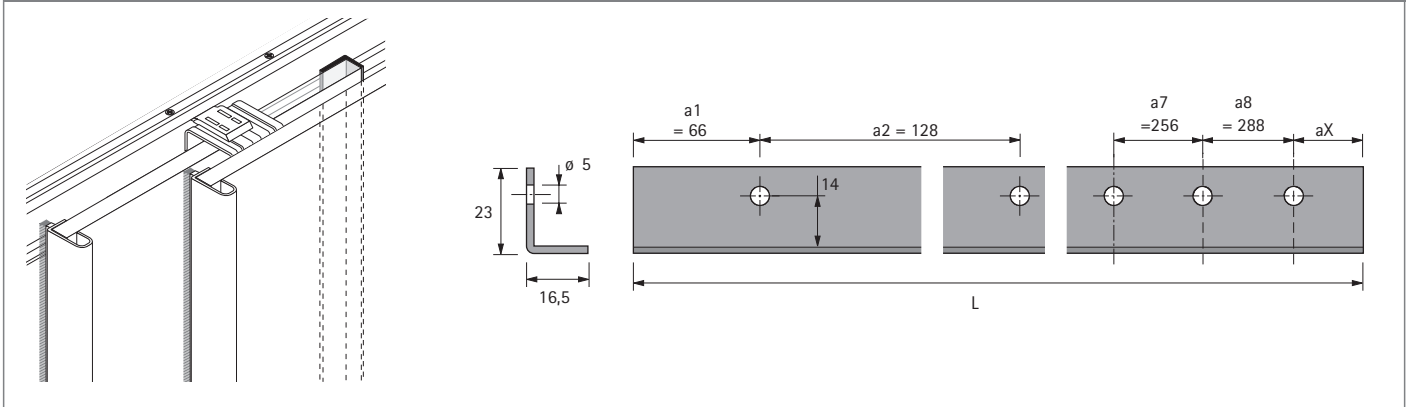

Door end profile, U shaped



- Predrilled
- For door thicknesses of 18 - 19 mm
- Customized lengths on request

Material	Finish	Length mm	Quantity for 3-doors	Order no.	PU
steel	silver, coated	individual	2	LA 10979	100 ea.
steel	silver, coated	2500	2	9 206 284	1 ea.
Aluminium	silver, anodized	2500	2	9 136 122	1 ea.

Installation / dimensional drawing

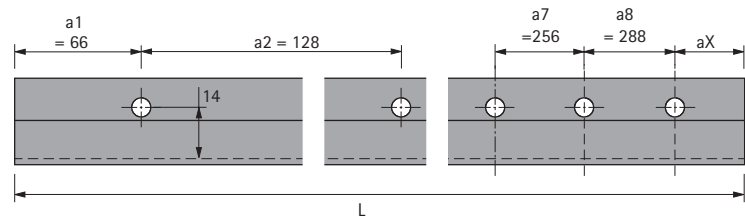
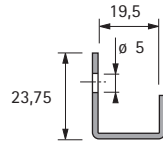
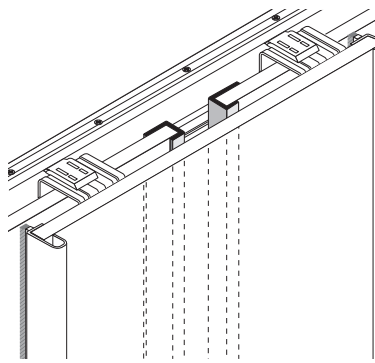

Carcase end profile for rear most door



- Predrilled
- Customized lengths on request

Material	Finish	Length mm	Quantity for 2-doors	Quantity for 3-doors	Order no.	PU
steel	silver, coated	2500	1	2	9 206 283	1 ea.
Aluminium	silver, anodized	2500	1	2	9 146 622	1 ea.

Installation / dimensional drawing

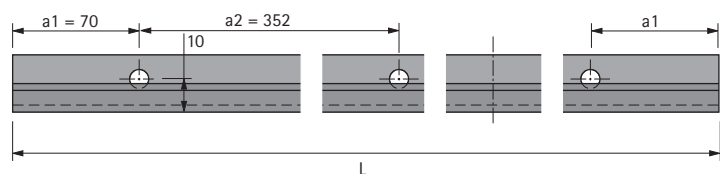
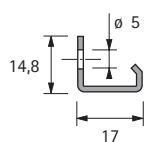
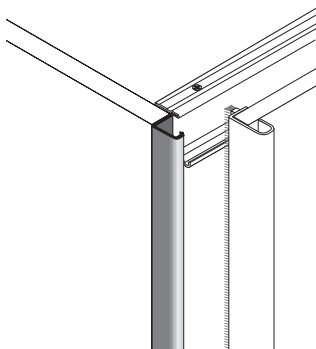

Carcase end profile for front most door



- Predrilled
- Customized lengths on request

Material	Finish	Length mm	Quantity for 2-doors	Order no.	PU
steel	silver, coated	2500	1	9 206 282	1 ea.
Aluminium	silver, anodized	2500	1	9 146 624	1 ea.

Installation / dimensional drawing

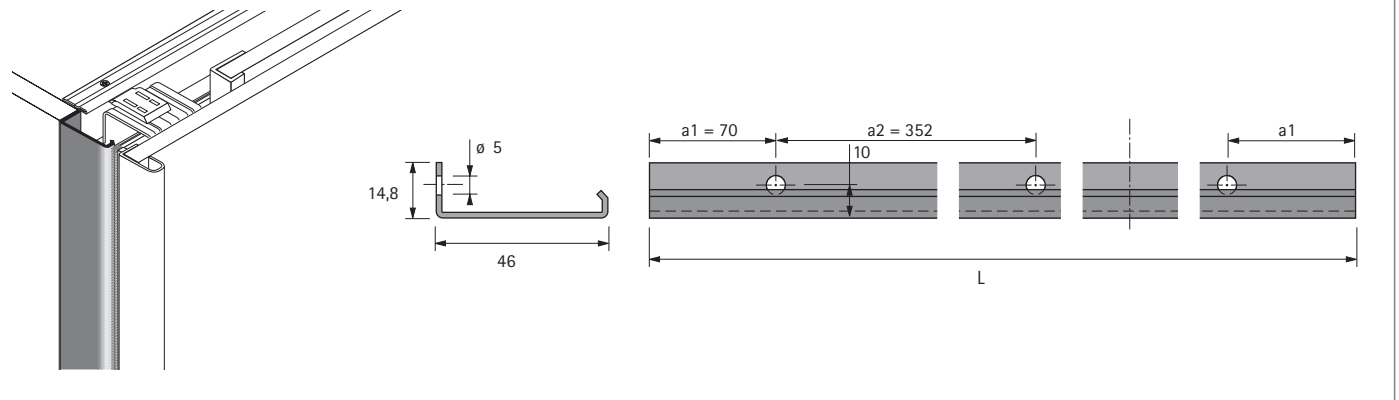

Brush sealing strip



- For dust proof covers
- Length 2500 mm
- Self adhesive
- Grey

Height mm	Quantity for 2-door	Quantity for 3-door	Order no.	PU
4.8	3	4	9 193 423	1 ea.
8	3	4	9 200 386	1 ea.
10	3	4	9 200 387	1 ea.

Installation / dimensional drawing

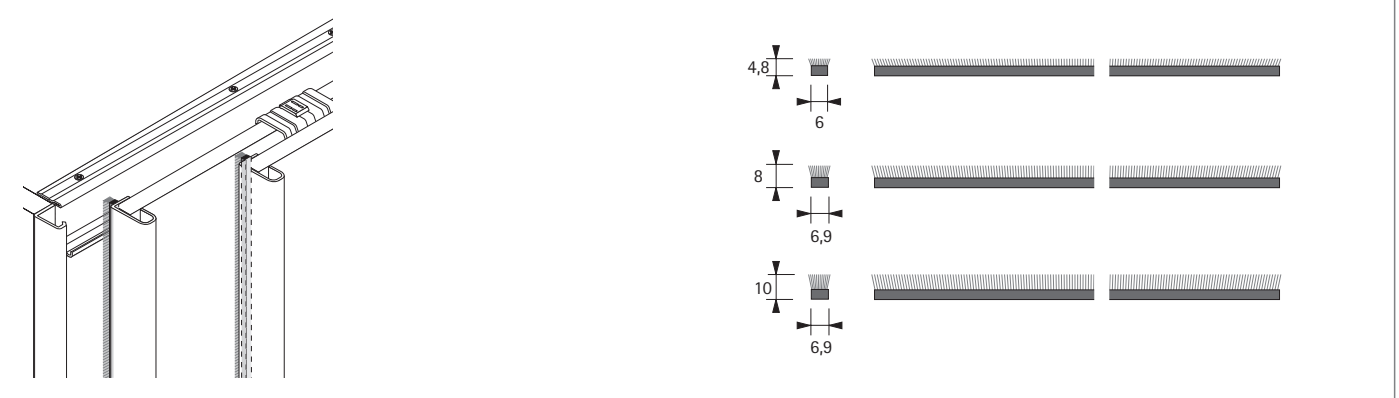

Connecting strap

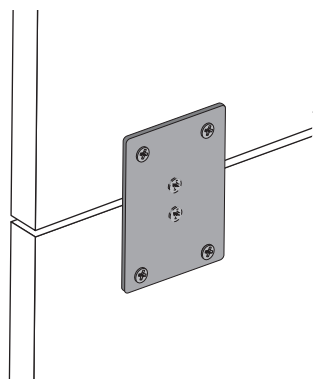

- For connecting segmented sliding doors
- Galvanized steel

Order no.	PU
9 117 506	1 ea.
9 110 132	300 ea.

Adjustment fitting, aluminium



- For straightening distorted furniture doors
- Can also be used as a precautionary measure to prevent doors from warping
- For door/front thicknesses of 16 - 25 mm
- Maximum door / front panel height 2600 mm
- Length of threaded rod 2000 mm, can be shortened as required
- Fast, screwless installation and adjustment requiring just one hand
- Patented system with encapsulated threaded rod
- For silent door / front movement
- Covers for \varnothing 35 mm drillings, plastic, silver
- Covers for groove, aluminium, silver anodized
- The adjustment fitting can also be used horizontally
- It is recommended that 2 vertical adjustment fittings are installed near the outer edge. On large, wide doors, 2 horizontal fittings can be used instead or in addition

Set comprises:

- 2 adjustment fittings

Order no.	PU
9 117 303	1 set

Technical information

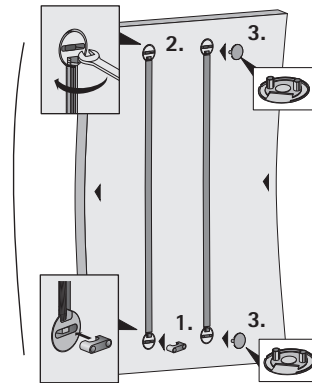
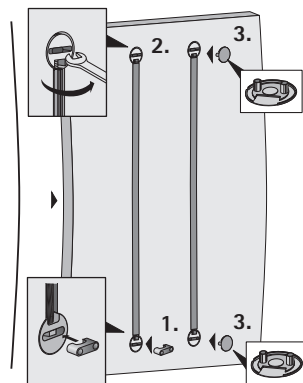
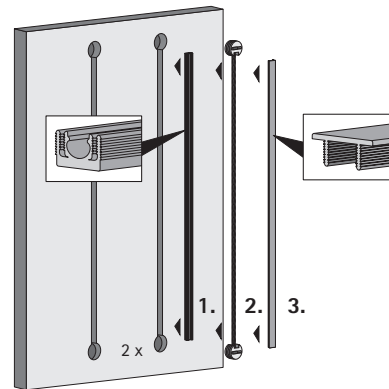
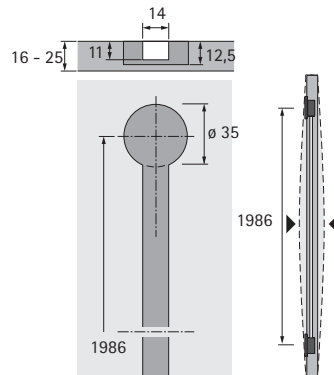

Adjustment fitting, plastic

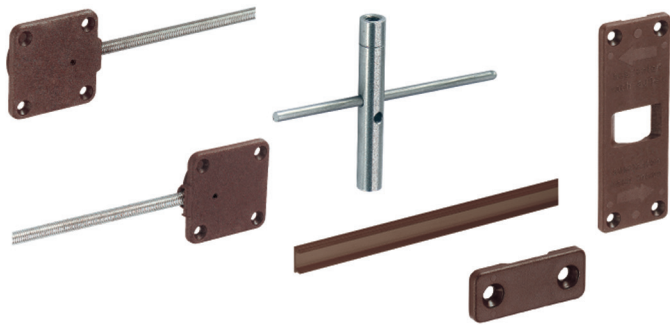

- For straightening distorted furniture doors
- Can also be used as a precautionary measure to prevent doors from warping
- For door / front panel thicknesses from 16 mm
- Maximum door / front panel height 2600 mm
- Installing the fitting is simple and straightforward: a pair of threaded rods, one with a right-hand thread and one with a left-hand thread, are fed into a clamping sleeve
- The threaded rods are each additionally supported in a housing that slots into a 35 mm drilling where it is screwed into place
- Turning the clamping sleeve produces tensile or compressive force that corrects warping or bowing
- The housing, clamping sleeve and threaded rods are covered to prevent damage to wardrobe and laundry
- The adjustment fitting can also be used horizontally
- It is recommended that 2 vertical adjustment fittings are installed near the outer edge. On large, wide doors, 2 horizontal fittings can be used instead or in addition

Set comprises:

- 1 housing with right-hand threaded rod
- 1 housing with left-hand threaded rod
- 1 clamping sleeve
- 1 plastic cover plate
- 2 plastic cover strips
- 2 retainers for cover strips

Order no.	PU
0 045 198	2 set

Technical information

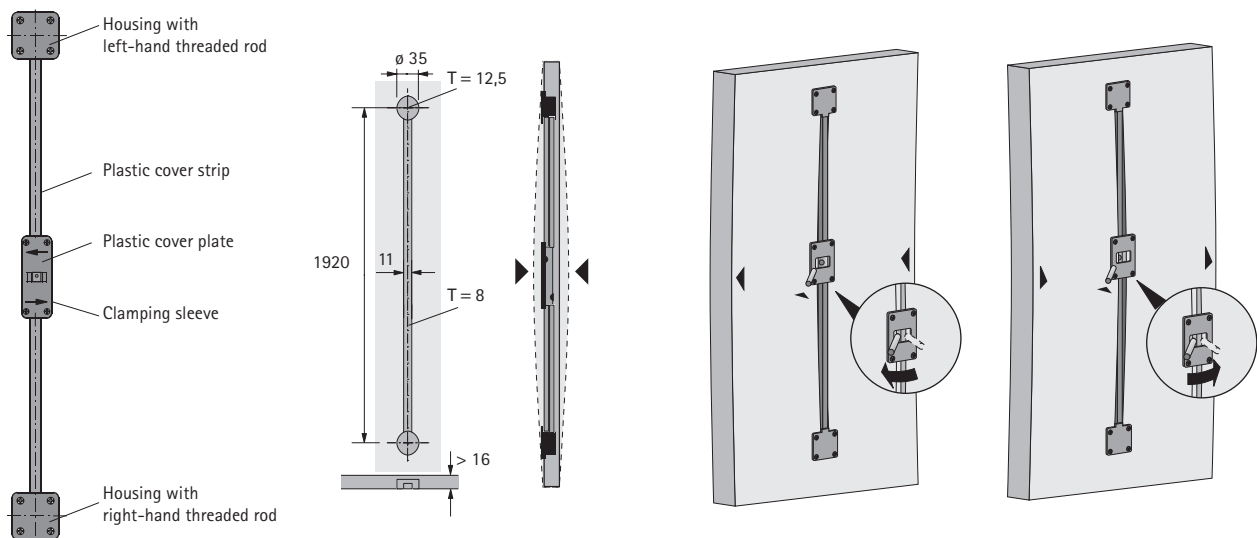

- ▶ Technical information
- ▶ Calculating door weights

Weight table for chipboard 19 mm

Door weight in kg (density = 700 kg/m³)

Door height mm	Door width mm														
	300	400	500	600	700	800	900	1000	1100	1200	1300	1400	1600	1800	2000
300	1,2	1,6	2,0	2,4	2,8	3,2	3,6	4,0	4,4	4,8	5,2	5,6	6,4	7,2	8,0
400	1,6	2,1	2,7	3,2	3,7	4,3	4,8	5,3	5,9	6,4	6,9	7,5	8,5	9,6	10,6
500	2,0	2,7	3,3	4,0	4,7	5,3	6,0	6,7	7,3	8,0	8,7	9,3	10,6	12,0	13,3
600	2,4	3,2	4,0	4,8	5,6	6,4	7,2	8,0	8,8	9,6	10,4	11,2	12,8	14,4	16,0
700	2,8	3,7	4,7	5,6	6,6	7,5	8,4	9,3	10,2	11,2	12,1	13,0	14,9	16,8	18,6
800	3,2	4,3	5,3	6,4	7,5	8,5	9,6	10,6	11,7	12,8	13,8	14,9	17,0	19,2	21,3
900	3,6	4,8	6,0	7,2	8,4	9,6	10,8	12,0	13,2	14,4	15,6	16,8	19,2	21,6	23,9
1000	4,0	5,3	6,7	8,0	9,3	10,7	12,0	13,3	14,6	16,0	17,3	18,6	21,3	23,9	26,6
1100	4,4	5,9	7,3	8,8	10,2	11,7	13,2	14,6	16,1	17,6	19,0	20,5	23,4	26,3	29,3
1200	4,8	6,4	8,0	9,6	11,2	12,8	14,4	16,0	17,6	19,2	20,8	22,3	25,5	28,7	31,9
1300	5,2	6,9	8,7	10,4	12,1	13,8	15,6	17,3	19,0	20,8	22,5	24,2	27,7	31,1	34,6
1400	5,6	7,5	9,3	11,2	13,0	14,9	16,8	18,6	20,5	22,3	24,2	26,1	29,8	33,5	37,2
1600	6,4	8,5	10,7	12,8	15,0	17,0	19,2	21,3	23,4	25,6	27,7	29,8	34,1	38,3	42,6
1800	7,2	9,6	12,0	14,4	16,8	19,2	21,6	24,0	26,3	28,7	31,1	33,5	38,3	43,1	47,9
2000	8,0	10,6	13,3	16,0	18,6	21,3	23,9	26,6	29,3	31,9	34,6	37,2	42,6	47,9	53,2
2200	8,8	11,7	14,6	17,6	20,5	23,4	26,3	29,3	32,2	35,1	38,0	41,0	46,8	52,7	58,5
2400	9,6	12,8	16,0	19,2	22,3	25,5	28,7	31,9	35,1	38,3	41,5	44,7	51,1	57,5	63,9
2600	10,4	13,8	17,3	20,8	24,2	27,7	31,1	34,6	38,0	41,5	45,0	48,4	55,3	62,2	69,2

Weight table for MDF 19 mm

Door weight in kg (density = 900 kg/m³)

Door height mm	Door width mm														
	300	400	500	600	700	800	900	1000	1100	1200	1300	1400	1600	1800	2000
300	1,5	2,1	2,6	3,1	3,6	4,1	4,6	5,1	5,6	6,2	6,7	7,2	8,2	9,2	10,3
400	2,1	2,7	3,4	4,1	4,8	5,5	6,2	6,8	7,5	8,2	8,9	9,6	10,9	12,3	13,7
500	2,6	3,4	4,3	5,1	6,0	6,8	7,7	8,6	9,4	10,3	11,1	12,0	13,7	15,4	17,1
600	3,1	4,1	5,1	6,2	7,2	8,2	9,2	10,3	11,3	12,3	13,3	14,4	16,4	18,5	20,5
700	3,6	4,8	6,0	7,2	8,4	9,6	10,8	12,0	13,2	14,4	15,6	16,8	19,2	21,6	23,9
800	4,1	5,5	6,8	8,2	9,6	10,9	12,3	13,7	15,1	16,4	17,8	19,2	21,9	24,6	27,4
900	4,6	6,2	7,7	9,2	10,8	12,3	13,9	15,4	16,9	18,5	20,0	21,6	24,6	27,7	30,8
1000	5,1	6,8	8,6	10,3	12,0	13,7	15,4	17,1	18,8	20,5	22,2	23,9	27,4	30,8	34,2
1100	5,6	7,5	9,4	11,3	13,2	15,1	16,9	18,8	20,7	22,6	24,5	26,3	30,1	32,9	37,6
1200	6,2	8,2	10,3	12,3	14,4	16,4	18,5	20,5	22,6	24,6	26,7	28,7	32,8	36,9	41,0
1300	6,7	8,9	11,1	13,3	15,6	17,8	20,0	22,2	24,5	26,7	28,9	31,1	35,6	40,0	44,5
1400	7,2	9,6	12,0	14,4	16,8	19,2	21,6	23,9	26,3	28,7	31,1	33,5	38,3	43,1	47,9
1600	8,2	10,9	13,7	16,4	19,2	21,9	24,6	27,4	30,1	32,8	35,6	38,3	43,8	49,3	54,7
1800	9,2	12,3	15,4	18,5	21,6	24,6	27,7	30,8	33,9	36,9	40,0	43,1	49,3	55,4	61,6
2000	10,3	13,7	17,1	20,5	23,9	27,4	30,8	34,2	37,6	41,0	44,5	47,9	54,7	61,6	68,4
2200	11,3	15,5	18,8	22,6	26,3	30,1	33,9	37,6	41,4	45,1	48,9	52,7	60,2	67,7	75,2
2400	12,3	16,4	20,5	24,6	28,7	32,8	36,9	41,0	45,1	49,3	53,4	57,5	65,7	73,9	82,1
2600	13,3	17,8	22,2	26,7	31,1	35,6	40,0	44,5	48,9	53,4	57,8	62,2	71,1	80,0	88,9

- ▶ Technical information
- ▶ Calculating door weights

Adjustment to different material thicknesses

The table entries refer to 19 mm thick material.
The table entries must be multiplied by a factor in order to adjust to material of different thickness.

Material thickness mm	Factor
15	0,79
16	0,84
18	0,95
19	1,00
20	1,05
22	1,16
23	1,21
26	1,37
29	1,53

Formula for conversion

Door weight = weight for door in thickness of 19 mm from table above x factor

Example

Chipboard door

H x W x D = 2000 x 1800 x 16

Weight shown in table for this door size, but material in a thickness of 19 mm = 47.9 kg

Convert to 16 mm door thickness using factor of 0.84 as shown in table on left

Door weight = 47.9 kg x 0.84 = 40.2 kg

Calculating weights of doors in alternative door materials

Density of various materials in kg/m³

Material	Density kg/m ³
Acrylic glass	1200
Aluminium	2700
Balsa wood	120
Concrete	2400
Lead	11300
Iron	7800
Gypsum plasterboard	900
Glass	2600
Hardboard	1000
Hardwood, wet (beech)	900
Hardwood, dry (beech)	800
Cork	300

To calculate the weight of doors in alternative door materials, the specific density of the door material must be taken into consideration.

Example

Door made of acrylic glass with a density of 1200 kg/m³
Door height: 2000 mm, door width: 1800 mm, material thickness: 6 mm

$$\begin{array}{c} \text{Door weight [kg]} \\ 25,9 \text{ kg} \end{array} = \begin{array}{c} \text{Height [m]} \\ 2 \end{array} \times \begin{array}{c} \text{Width [m]} \\ 1,8 \end{array} \times \begin{array}{c} \text{Material thickness [m]} \\ 0,006 \end{array} \times \begin{array}{c} \text{Density [kg/m}^3\text{]} \\ 1200 \end{array}$$

Sliding door systems

- ▶ Technical Information
- ▶ Design advice

Always the best system

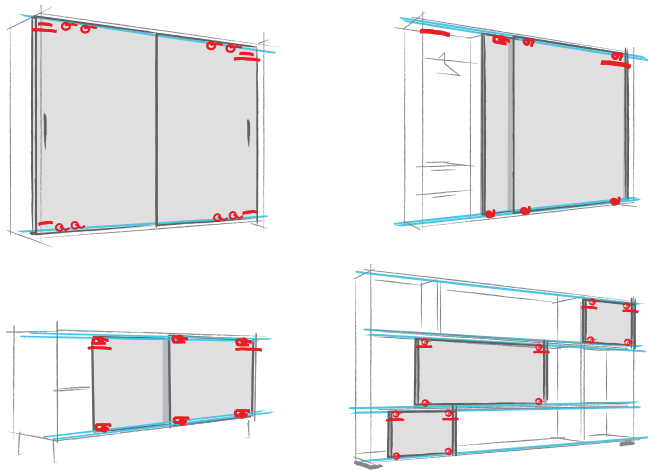

Hettich sliding door systems give you the ideal solution to meet any consumer demand, because Hettich offers you numerous system options. Each design provides its own particular benefits and creative impact on the piece of furniture. Take advantage of Hettich sliding door systems for all cabinets and shelf units. We are now going to give you a brief introduction to the various systems, so you can quickly find the main criteria for selecting the right sliding door system.

Option 1: 1-track or multi-track sliding doors

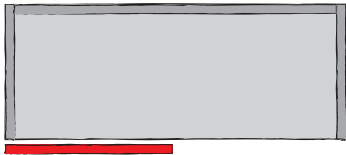

1-track sliding doors do not close off furniture completely. The door only conceals individual furniture segments and can be pushed to the side. Typical application: the living room combination in which the TV set disappears behind the sliding door after use.

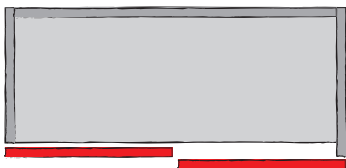

Multi-track sliding doors can close off the entire furniture carcass. At least two doors run in profiles installed one behind the other. Ideal for office cabinets, wardrobes and pantry units: the closed doors conceal the cabinet's entire contents, creating a neat and tidy look in a matter of seconds.

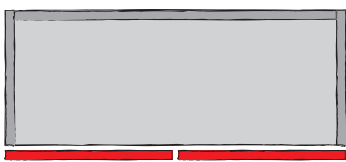

Flush fitted sliding doors are a special innovative type that also close off the complete carcass. The closed cabinet front panel forms an absolutely flat surface, reducing reveals to a minimum. An option for the most exacting demands on design. The doors run in a single track; on opening, however, a special mechanism automatically allows them to run one behind the other.

Option 2: overlay or inset sliding doors

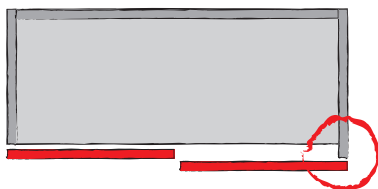

Overlay sliding doors conceal – viewed from the front – the carcass side, the top panel and bottom panel. This makes the front panels the dominant design element of a piece of furniture. Please note: for furniture designed with two doors, the two carcass sides must be produced in different depths.



Inset sliding doors, in contrast, move between the carcass sides, the top panel and the bottom panel. The carcass elements are visible from the front, also influencing the design of furniture. The carcass sides are of identical depth.

Sliding door systems

- ▶ Technical Information
- ▶ Design advice

Option 3: bottom running or top running sliding doors

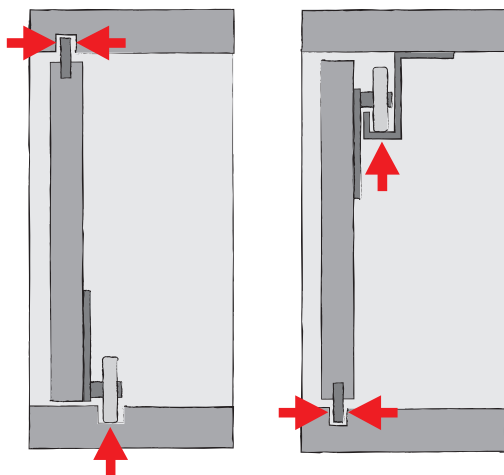

Bottom running sliding doors stand on rollers along their bottom edge and are stabilised by a guide at the top edge of the door. Given the uncomplicated carcass construction, predominantly low door weights and straightforward installation, bottom running doors are seen as the optimum gateway to constructing sliding door cabinets.

Top running sliding doors are suspended from the top panel. A guide at the bottom panel prevents the doors from wobbling. The fitting components can be positioned unobtrusively at the top and bottom panel – for furniture designed with a look of harmony. Top running sliding doors are ideal for heavy doors, e.g. in large wardrobes.

Option 4: installing sliding doors on or in front of the top panel

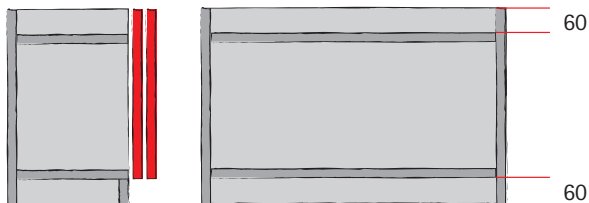

With a simple trick, the fitting technology can be installed largely **out of view on the top panel**: the top panel is lowered by 60 mm. Proviso: the piece of furniture is a tall cabinet with a top panel that is positioned out of sight.

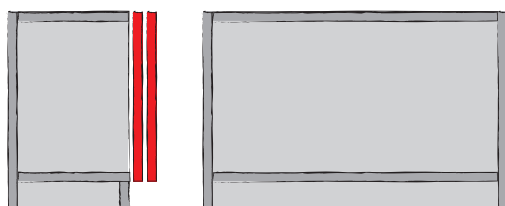

On low cabinets, the top panel is always visible. In this case, carcass and top panel are conventionally mounted at right angles and the fitting technology is either attached **in front of or in the top or bottom panel**. The doors close flush at the top – a neat looking solution. Incidentally: the cabinet here is designed in the same way as hinged door cabinets. Benefit: subsequent conversion from hinged door to sliding door system can be done with little effort.

Option 5: sliding door format and material

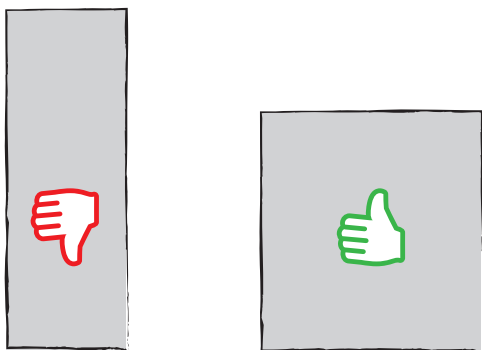

Key to selecting the appropriate system: format and material of the sliding door. In terms of format, bear in mind that wider doors run far more stably than narrow, tall sliding doors. Rule of thumb: the sliding door width should be at least half the height of the door.

Sliding door systems

- ▶ Technical Information
- ▶ Design advice

Definition of important dimensions

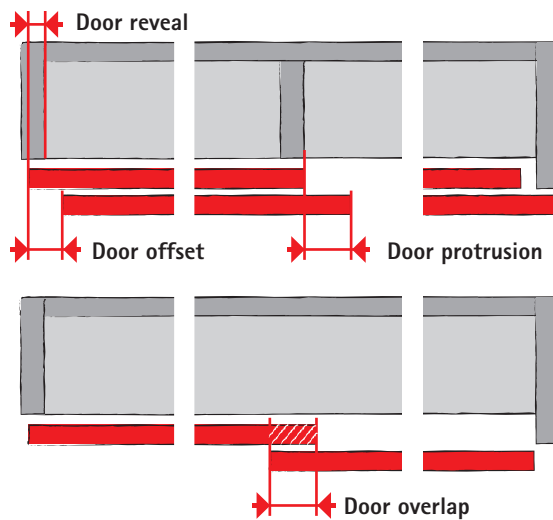

The **door reveal** is the extent to which the door overlaps the carcass side.

The **door protrusion** is the measure of opened door offset to the centre panel.

The **door offset** prevents the forward door from knocking against the handle on the rear door.

Door overlap is the surface of the rear most door that is permanently covered by the front most door. The overlap should be approx. twice as large as the gap between front most door and rear most door to avoid being able to see inside the cabinet through the gap. On aluminium framed doors, frame width is often taken as the overlap. This positions the upright frame sections of the front most door and rear most door exactly in front of one another down the middle of the cabinet.

Door reveal as a variable influencing door protrusion

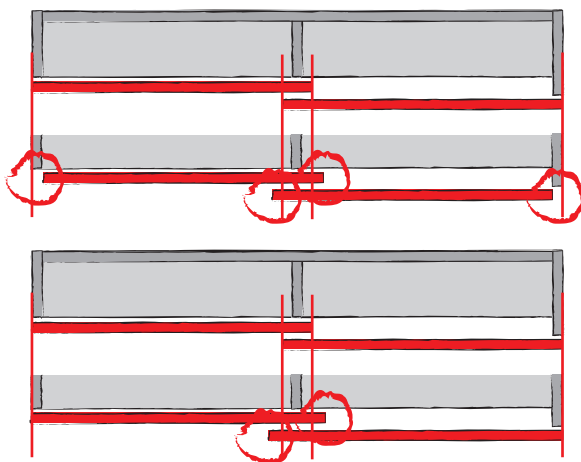

Reducing the door reveal increases the door protrusion on doors of identical width.

Increasing the door overlap on account of a larger door increases the door protrusion.

The centre panel as a variable influencing door protrusion

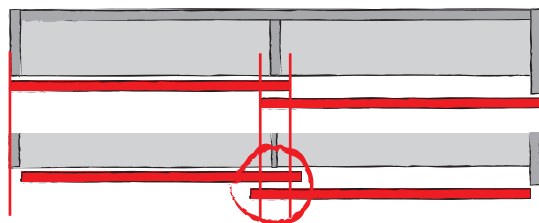

A thinner centre panel increases the door protrusion on doors of identical width.

Design with flush opening doors

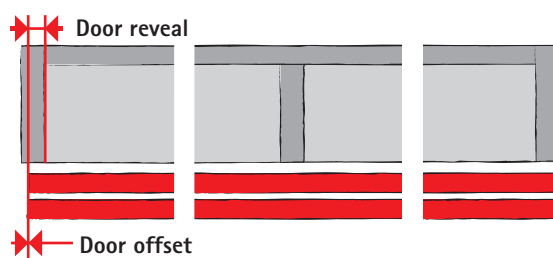

The rear door must produce the same door reveal as the forward door. It must be noted here that this requires the use of special profiles.

Sliding door system

- ▶ Technical information
- ▶ Quality criteria

Quality that meets all the demands

The quality of the sliding door systems is monitored continuously. Hettich fittings comply with the national and international quality standards of the markets our customers operate in. The diagrams below show some of the tests to which Hettich fittings are subjected.

Load capacity

The values stated in the catalogue for Hettich sliding door systems comprise the permissible total weight of the door in combination with the permitted door sizes. All Hettich sliding door systems pass the overload test to EN 15706¹. The sliding door systems are suitable for furniture to EN 14749 when processed correctly as specified in the catalogue.

Corrosion test

Hettich sliding door systems satisfy the requirements on corrosion defined in EN 15706, 72-hour condensation-water test to EN 6270.

¹ TopLine 1200 / 1210 / 1230 meets the requirements of ANSI / BHMA

Endurance test

The door must withstand a defined number of opening and closing cycles at a defined speed.

- Level 1: 10,000 cycles
- Level 2: 20,000 cycles
- Level 3: 40,000 cycles

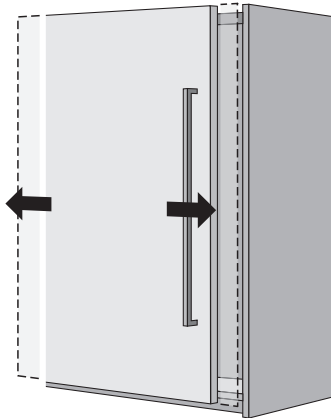

Lift off guard

The door is pulled up and forwards at an angle with a defined force and must not become detached or fall out of the cabinet

- Level 1: 150 N
- Level 2: 200 N
- Level 3: 250 N

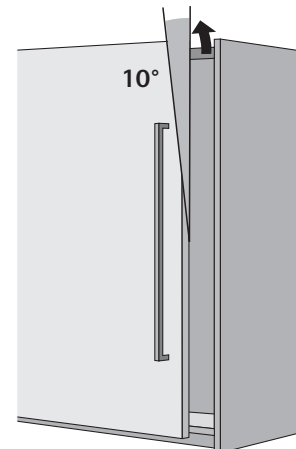

Closing test

The door must withstand a specific number of closing cycles under a defined tensile load.

- Level 1: 2 kg
- Level 2: 3 kg
- Level 3: 4 kg

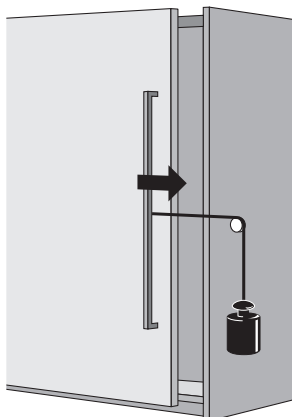

Horizontal safety test

Pressure is applied to the middle of the door with a defined force. The door must not become detached or fall out of the carcass.

- Level 1: 150 N
- Level 2: 200 N
- Level 3: 250 N

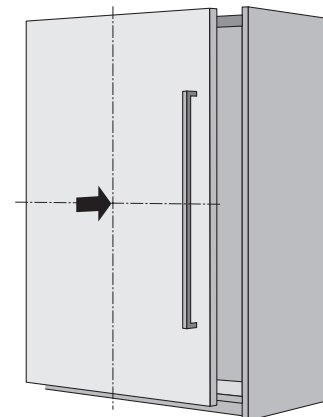

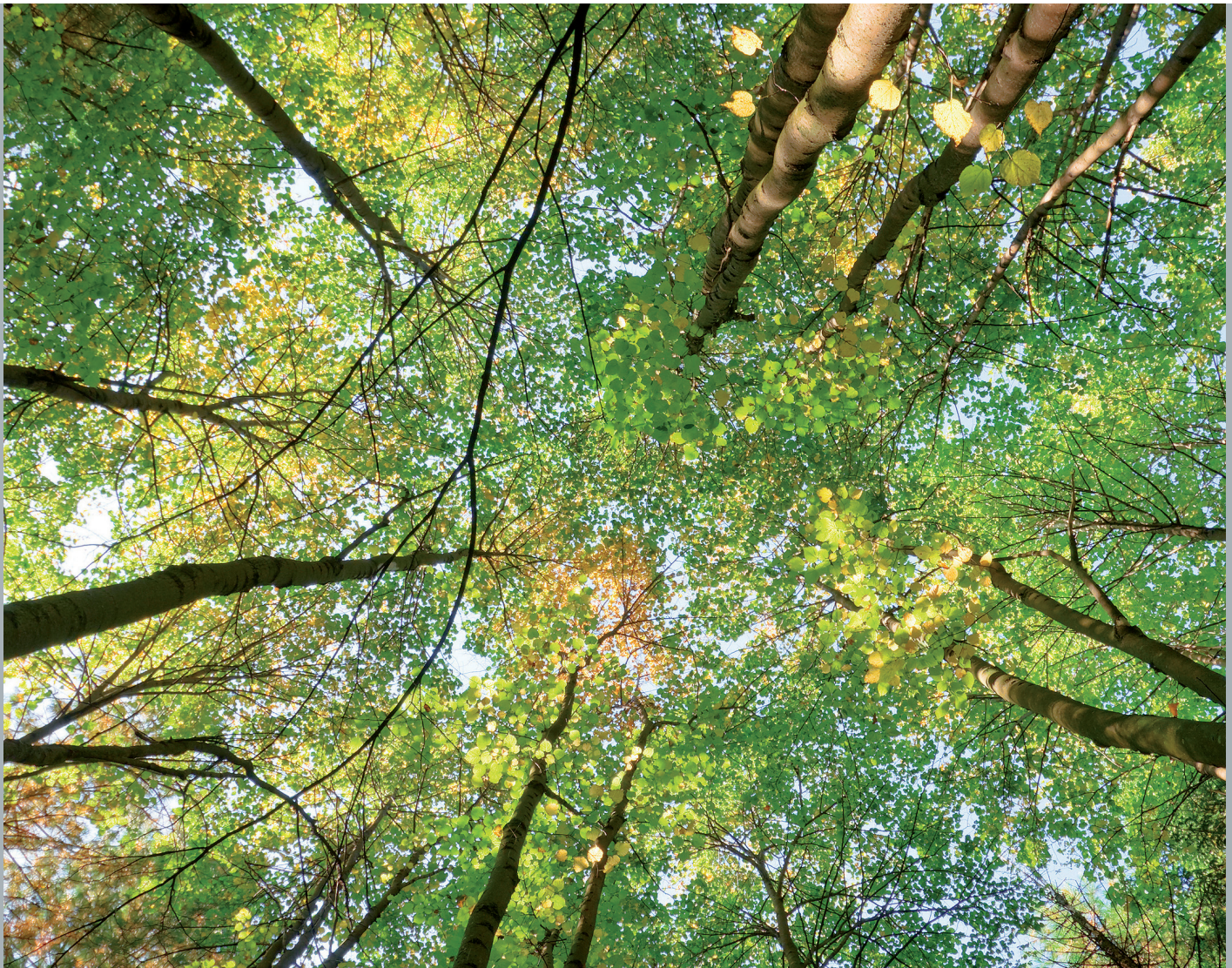

Hettich takes a responsibility for the world we live in. This awareness defines the strict policy of environmental management that we practise. Our environmental officer has taken personal responsibility for these aspects throughout the group of companies over a period of many years. In addition, a separate environment committee has been established for each production site. We regard statutory provisions as minimum requirements. At significant sites we also implement the stringent EMAS Regulation. And we drive forward developments that in future will help to save even more raw materials and support the necessary endeavours towards sustainability.

Hettich environmental management

In 1996 Hettich started introducing effective environmental management systems under the stringent EMAS Regulation (currently: EC Regulation No. 761/2001, including EN ISO 14.001/2004). This not only enables us

to improve our environmental performance on a broad front but also to achieve a high level of safety which, not least, also benefits our customers. This is why we also require our suppliers to meet the necessary minimum standards of environmental protection, industrial safety, health care and social welfare.

The results achieved in the drawer runner and drawer system product segment at the Kirchlegern operation in Germany illustrate the impressive effects these measures have and verifiably demonstrate our tireless endeavours to translate words into action:

Relief to the environment between 1997 and 2008:

Specific water consumption:	56 per cent
Specific power consumption:	21 per cent
Specific heat consumption:	84 per cent
Specific CO ₂ emissions:	29 per cent

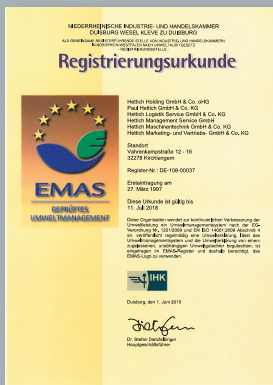

Hettich standard for product materials

Hettich underpins its commitment by applying an internal standard for product materials. This ensures that every product – from production to disposal – satisfies all environmental requirements. Hettich products are durable. Appropriately foresighted, our rigorous standards are formulated to ensure that international legislation is also met. This provides a reliable base for marketing furniture worldwide.

Zero-energy building – Hettich Forum

The Hettich Forum building with its neutral energy balance is a shining example of future-proof building design. Photovoltaic panels and a solar collection system providing hot water as well as extensive roof greening and use of rain water underscore this building's overall sustainability

concept in just the same way as the broad use of cellulose insulation material from recycled newspapers, highly efficient heat recovery and the bulb-free lighting concept do.

With the Hettich Group having acquired European Commission GreenBuilding Partner status on 5 March 2009, the comprehensive approach demonstrated by the Hettich Forum has also convinced the adjudicating panel of the national "Green Building Award 2009". Hettich received the first prize to be presented in the "New Building" category.

Technik für Möbel



www.hettich.com

Order no. 9160543
1604-026_TopLine M_0516_HUS/en

Hettich America, L.P.
4295 Hamilton Mill Road
Suite 400
Buford, GA 30518
Phone: 1-800-438-8424
Fax: 1-800-627-5152
info@hettichamerica.net

Technik für Möbel

