



**TRADEMARK
HARDWARE**

WORLD OF QUALITY HARDWARE

PRODUCT SPECS

Door Leaf Capacity - Up to 200 lbs.

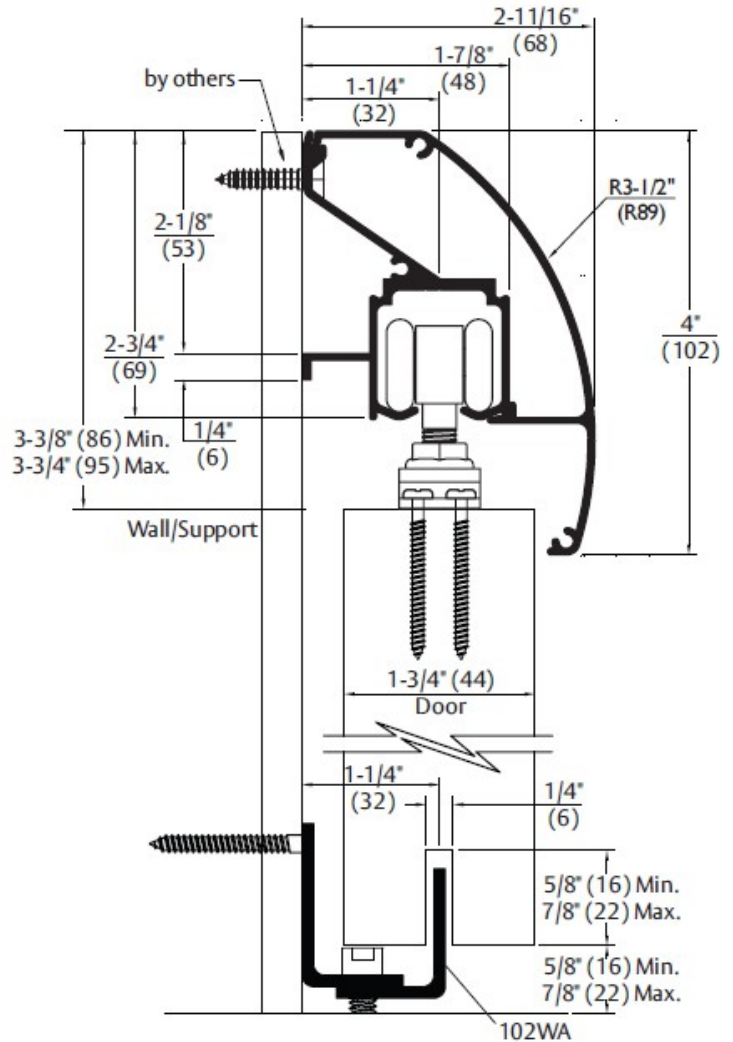
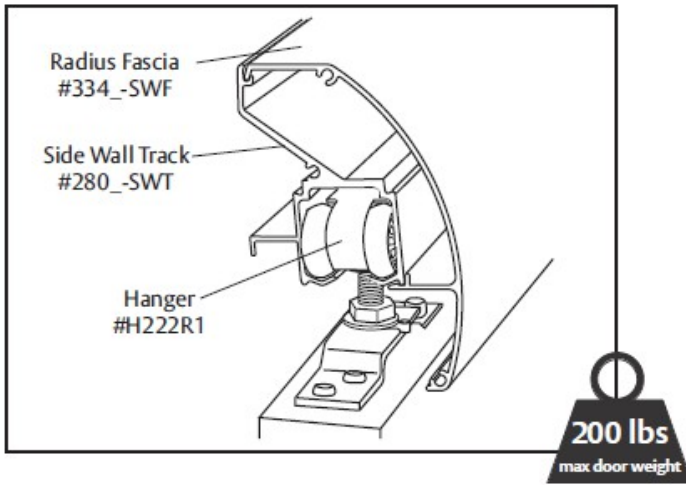

(A) Max. Door Width	(L) Run
30°	60°
36°	72°
48°	96°
2 @ 36°	144°

Kit No.	Material	Max Leaf Width
RF280C-SWTK/6	mill finished track / 6'	36°
RF280C-SWTK/8	mill finished track / 8'	48°
RF280C-SWTK/12*	mill finished track / 12'	2 @ 36°
RF280D-SWTK/6	dark bronze track / 6'	36°
RF280D-SWTK/8	dark bronze track / 8'	48°
RF280D-SWTK/12*	dark bronze track / 12'	2 @ 36°

*NOTE: RF280_-SWTK/12 comes with enough hardware for two doors.

SKU: RF280C-SWTK



www.tmhardware.com



845-388-1300



845-388-1388



sales@tmhardware.com