

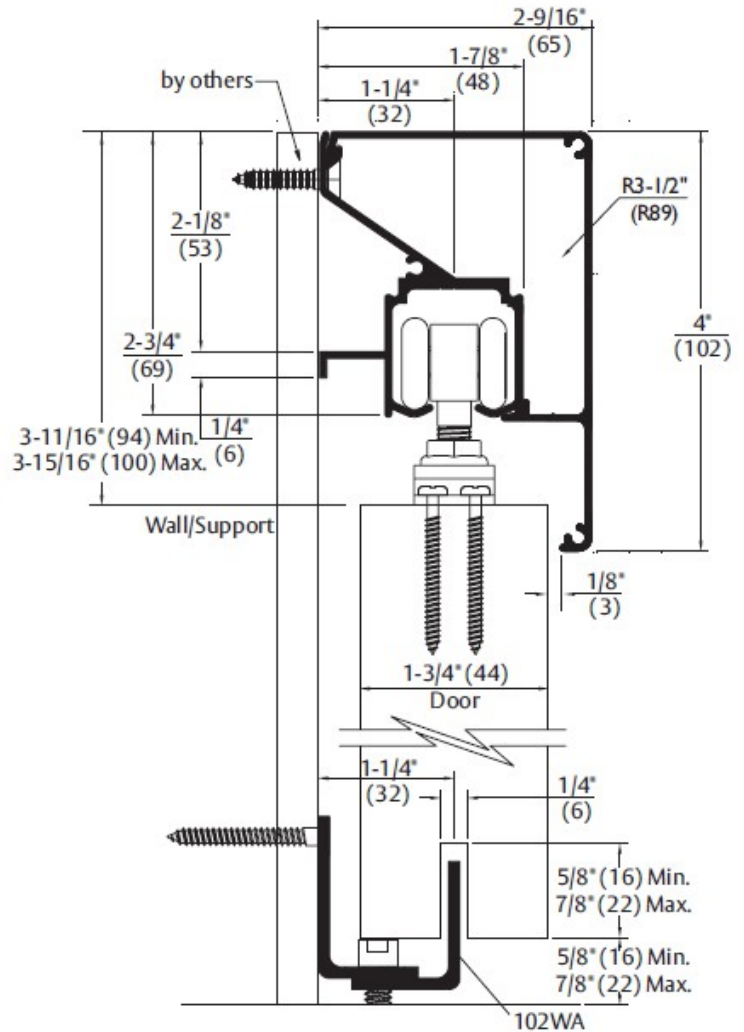

**TRADEMARK  
HARDWARE**

WORLD OF QUALITY HARDWARE

# PRODUCT SPECS

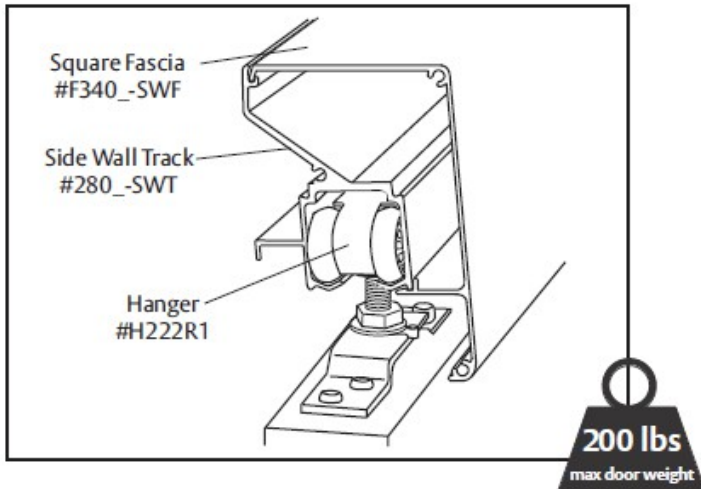

(A) Max. Door Width	(L) Run
30"	60"
36"	72"
48"	96"
2 @ 36"	144"

Kit No.	Material	Max Leaf Width
SF280C-SWTK/6	mill finished track / 6'	36"
SF280C-SWTK/8	mill finished track / 8'	48"
SF280C-SWTK/12*	mill finished track / 12'	2 @ 36"
SF280D-SWTK/6	dark bronze track / 6'	36"
SF280D-SWTK/8	dark bronze track / 8'	48"
SF280D-SWTK/12*	dark bronze track / 12'	2 @ 36"

\*NOTE: SF280\_-SWTK/12 comes with enough hardware for two doors.

## SKU: SF280C-SWTK



www.tmhardware.com



845-388-1300



845-388-1388



sales@tmhardware.com