



Self closing system for a single door between 800 to 1200mm wide. For metal or timber doors with a thickness between 30mm and 46mm. Complete with a hydraulically controlled soft close feature, and a brake to reduce opening speed to prevent damage to the door and system. Consistent hydraulic closing operational range between temperature ranges of -10°C to 40°C.

(Read instructions thoroughly before commencing installation).

Parts List

Part	Qty
1 Aluminium track 2200mm	1
2 Leading hanger	1
3 Trailing hanger	1
4 Hydraulic Control Unit	1
5 Closing brake rack	1
6 Opening brake rack	1
7 Power spring mounting bracket	1
8 Height adjustment plates	7
9 Power spring unit	1
10 M5 X 16 pan head screw	10
11 M8 x 35 hexagon bolt	4
12 M5 x 12 pan head screw	2
13 Anti rise bolt	2
14 Spring washer (Countersunk 10mm dia)	2
15 M5 X 12 pan head screw	2
16 M4 X 6 pan head screw	2
17 Guide roller	1
18 Opening door stop	1
18 Door stop roller	1
18 M6 X 20 Hexagon bolt	1
18 M5 X 12 pan head screw	2
19 Closing door stop	1
20 Wooden door plate	2
20 Ø5 X 30 screws (Countersunk flat head)	8
21 Delayed timer body (optional)	1
21 Time adjusting plate (optional)	1
22 Guide channel (optional)	1

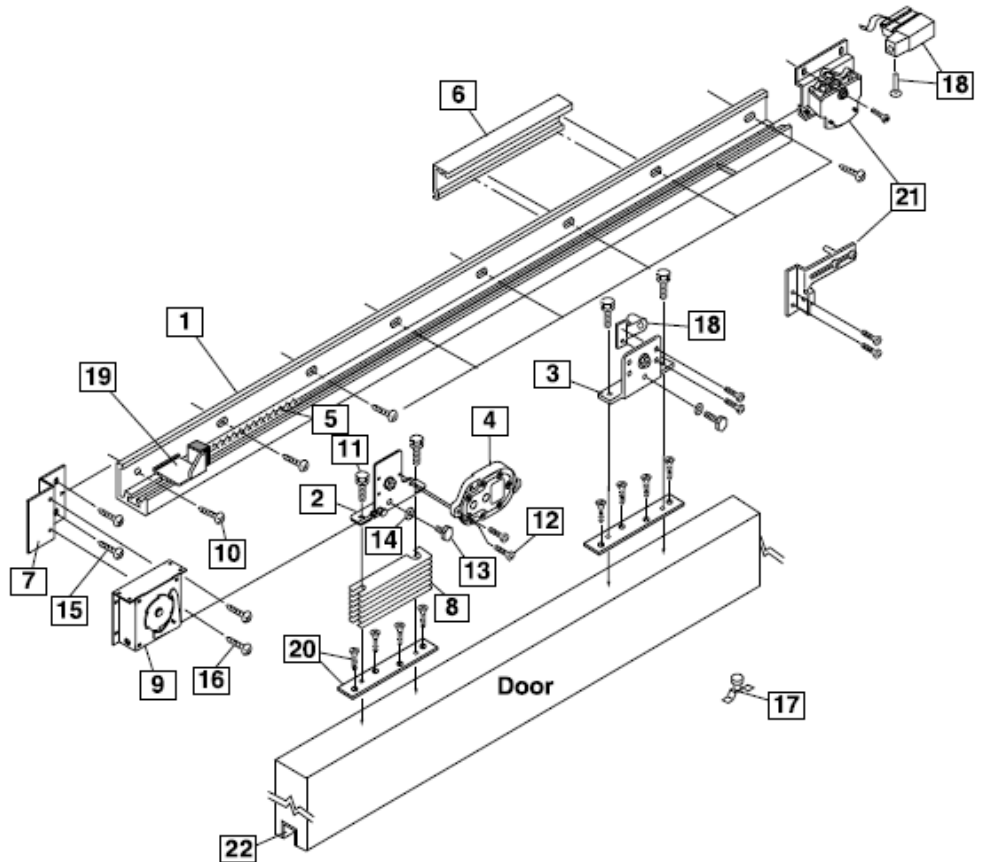

Tools Required

Spirit level, Posi-drive screwdriver, Flat head screwdriver, Metal cutting saw, Drill with metal and masonry drill bits and a Tape measure

General Elevation of Completed Installation

The elevation view is showing right hand opening of the door. Left hand opening is simply a mirror image. Right hand closing is shown in all images.

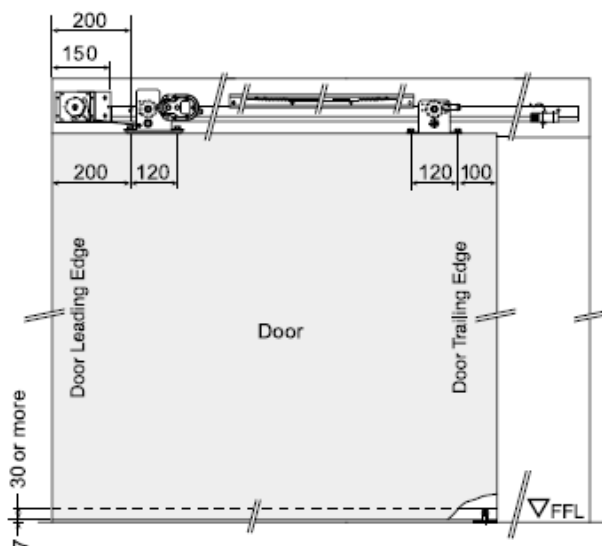



1. Cutting the Track

The track must be cut 180mm shorter than twice the door width. After cutting the track check the location of the last pre-drilled screw hole if it is more than 100mm from the track cut edge then drill a new hole 5.5mm diameter 50mm from the cut edge as shown in diagram 1.

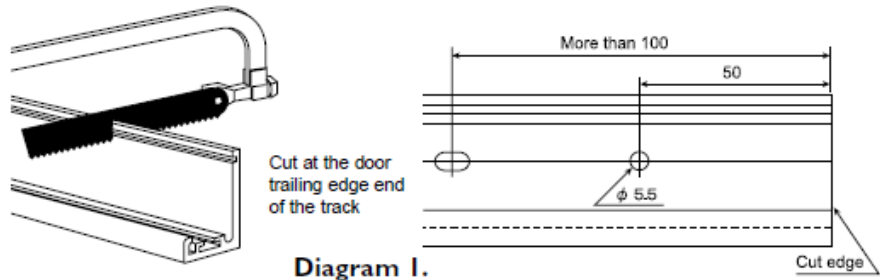

Diagram 1.

2. Leading Edge Door Stop

Slide the Leading Edge Door Stop into the groove in the track to the desired position. Mark on the underside of the track the position of the 'V' mark on the stop body and move the stop clear of the mark. Drill a 6.5 dia hole as shown in diagram 2a. Reposition the stop and secure in position by tightening the M4 x 12 screw located on the top of the stop and fitting the M6 x 20 bolt through the bottom of the track into the stop body as shown in diagram 2b.

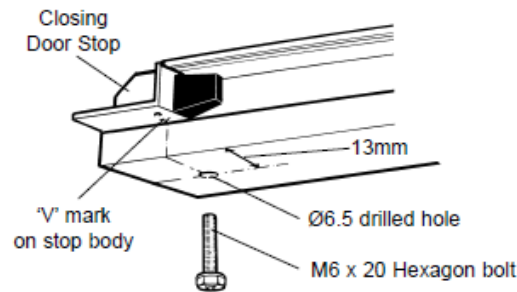

Diagram 2a.

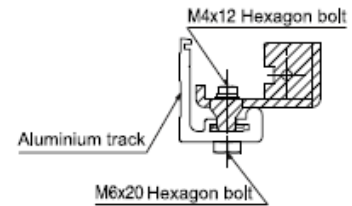

Diagram 2b.

3. Trailing Edge Door Stop

If using the optional Delayed Timer then do not fit the stop, refer to the instructions for the Delayed Timer.

Slide the Trailing Edge Door Stop into the groove in the track to the desired position. Mark on the underside of the track the position of the 'V' mark on the stop body and move the stop clear of the mark. Drill a 6.5 dia hole as shown in diagram 3a. Reposition the stop and secure in position by tightening the M4 x 12 screw located on the top of the stop and fitting the M6 x 20 bolt through the bottom of the track into the stop body as shown in diagram 3b.

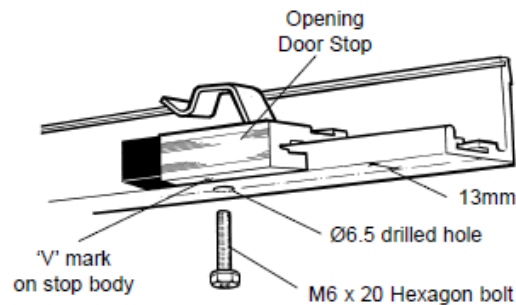

Diagram 3a.

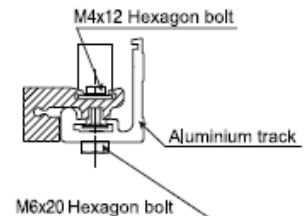

Diagram 3b.





4. Fitting the Track to the Wall

Mark out and drill the Reference Hole 200mm from the leading edge of the door when it is in the closed position, and at a height from the FFL as detailed in diagram 4a. Refer to dimension B in relation to door material type. Mark out and drill all of the extra wall fixing holes at intervals of 300mm as also shown in diagram 4a. Fix the track to the wall as shown in diagram 4b.

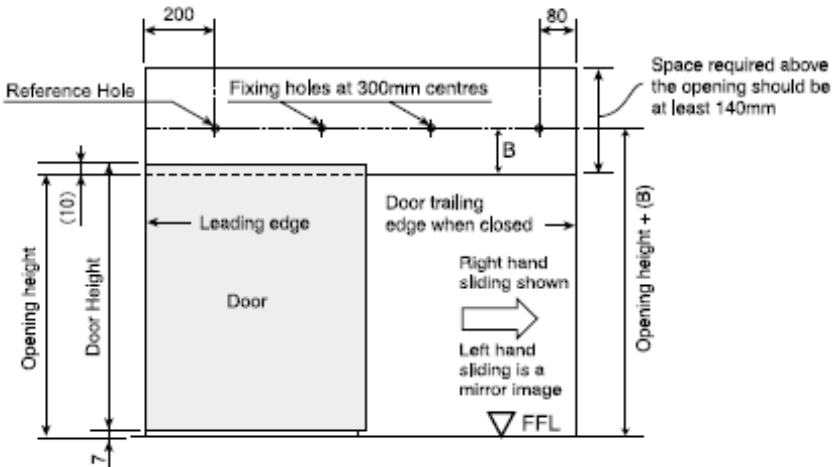

Diagram 4a.

Dimension B	B
For Steel Doors	72
For Timber Doors	78

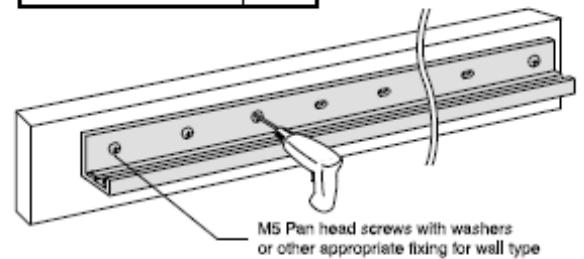

Diagram 4b.

5. Installation of the Power Spring Unit

Place the mounting bracket so it is touching the edge of the track. Adjust the height of the bracket to align the marker point with the track as shown in diagram 5a. Fix the bracket to the wall with M5 x 12 screws or other appropriate fixing for the wall type. There must be no gap between the bracket and the track when fixed to the wall as shown in diagram 5b.

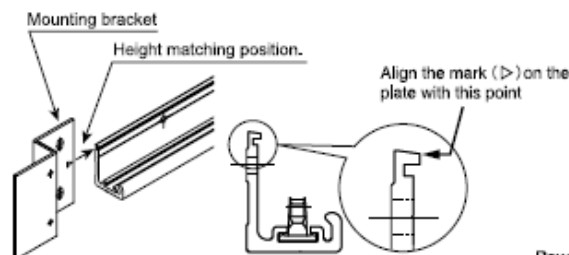

Diagram 5a.

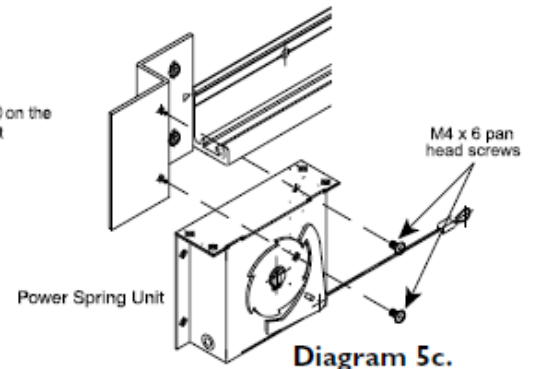

Diagram 5c.

Fix the Power Spring Unit to the mounting bracket with the M4 x 6 pan head screws supplied as shown in diagram 5c. Refer to diagram 5d to check Power Spring Unit fixed position.

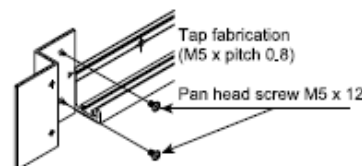

Diagram 5b.

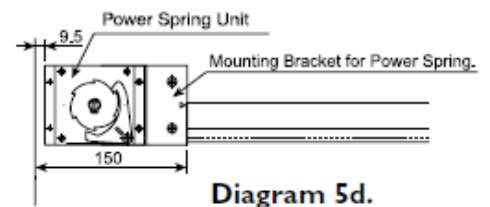

Diagram 5d.





6. Fitting the Hangers to the Door

For fixing the hangers to metal doors first fix the leading hanger with the M8 x 35 bolts provided with the 7 height adjustment plates as shown in diagram 6a. Then fix the trailing hanger also shown in diagram 6a. For fixing the hangers to timber doors first drill the four 9mm dia holes into the top of the door as shown in diagram 6b. Fix the steel plates with the $\varnothing 5 \times 30$ wood screws making sure the 9mm holes drilled in the top of the door are aligned with the clearance holes in the plates. Fix the hangers to the plates as previously described and shown in diagram 6a including the 7 height adjustment plates. Ensure the hangers are fixed squarely and in line with the door as shown in diagram 6c.

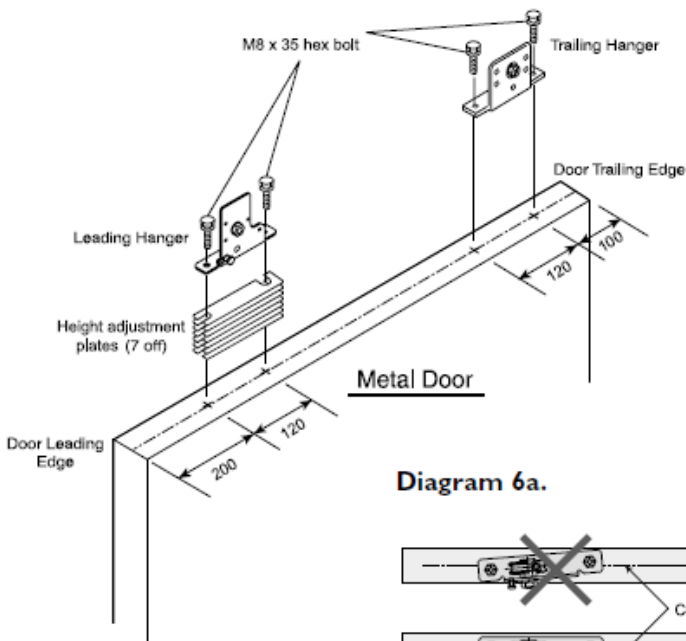

Diagram 6a.

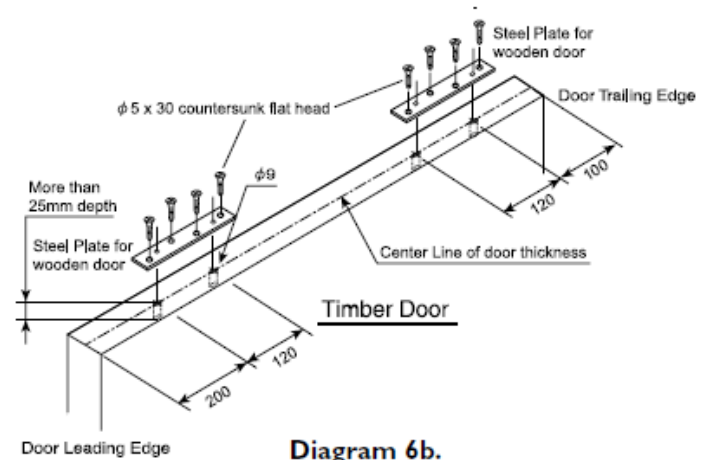

Diagram 6b.

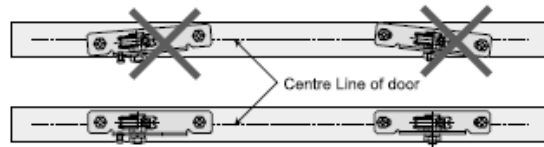

Diagram 6c.

7. Fitting the Guide System

Fit the Guide Roller to the floor with suitable fixings in the position shown in diagram 7a. If required install the optional guide channel into the bottom of the door as shown in diagram 7b. Fix the channel into position with the screws provided.

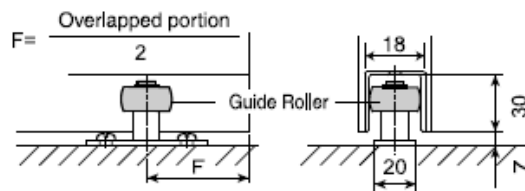
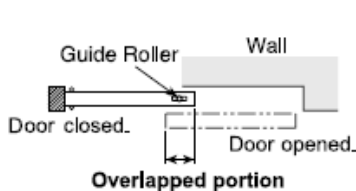

Diagram 7a.

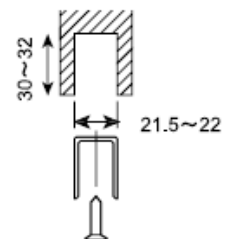

Diagram 7b.





8. Hanging the Door

With the track and the hangers firmly fixed in position, hang the door on to the track whilst locating the floor guide into the guide channel in the bottom of the door. Carefully check the door can slide smoothly and that there are no clearance problems.

Install the hanger anti-rise bolts to both of the hangers as shown in diagram 8.

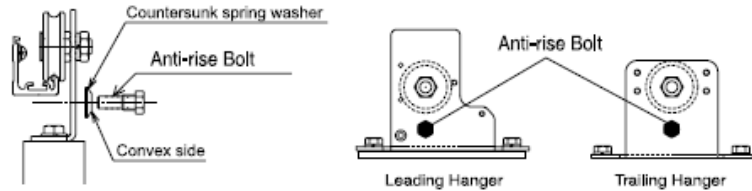

Diagram 8.

9. Installation of the Opening Brake

Slide the door to the fully open position, insert the Opening Brake Rack into the groove on the track as shown in diagram 9a. Then align the front edge of the leading hanger with the aligning mark on the brake rack as shown on diagram 9b. Screw the rack to the wall through the four holes in the rack with suitable fixings. Remove all debris from the track as this will damage the track and the rollers.

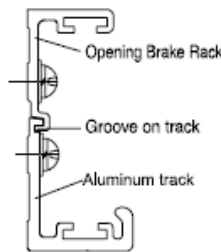

Diagram 9a.

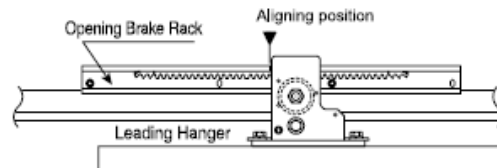

Diagram 9b.

10. Installation of the Hydraulic Control unit

With the door in the closed position fix the Hydraulic Control Unit to the leading hanger as shown in diagram 10a with the M5 x 12 screws provided. Pull the control wire from the Power Spring Unit and hook the wire loop on to the leading hanger body as shown in diagram 10b.

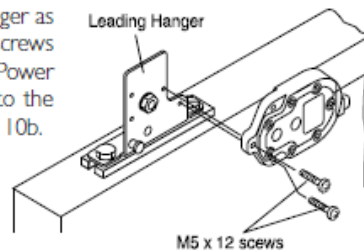

Diagram 10a.

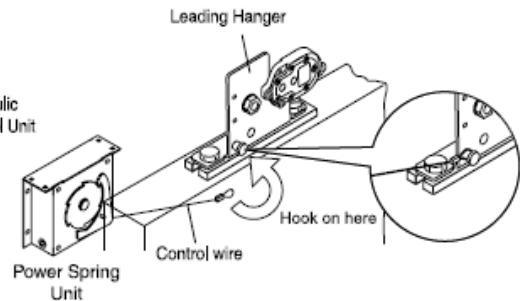

Diagram 10b.

11. Adjusting the Closing Power and Speed

Adjust the closing power by firstly removing the fixing screw. Adjust the Power Spring Unit as shown in the diagram 11a. When complete re-tighten the fixing screw back into its original position as shown in diagram 11a. Diagrams shown are for right handed sliding doors, for left handed sliding doors the procedures are the opposite.

To adjust the door closing speed as shown in diagram 11b. Perform this calibration about 250mm from the fully closed position with a flat head screwdriver, and then ensure that the door closes with an appropriate and safe speed from the fully opened position. Do not turn the speed adjustment valve more than two full revolutions.

To make pulling power stronger

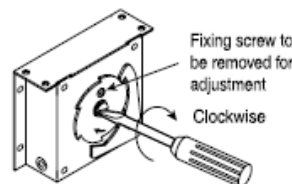

Diagram 11a.

To make pulling power weaker

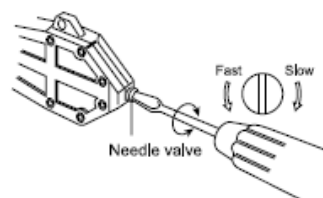
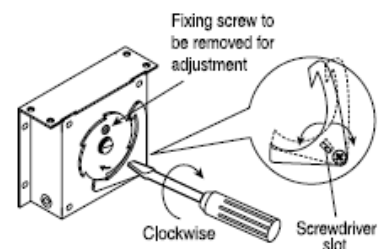

Diagram 11b.