

BI-FOLD - 9890 & 9891 PACKAGED SETS

FEATURES

- Heavy duty aluminum box track and hardware
- Conforms to ANSI A156.14
- Type: D8621, D8641, D8651, D8661

SPECIFICATIONS

- For doors 1-1/8" - 1-3/4" (29 mm - 44 mm) thick
- Quick release hanger allows easy door hanging and removal
- Up to 125 lbs (57 kg) per panel bi-fold
- Up to 75 lbs (34 kg) per panel multi-fold
- Track is extruded aluminum jump-proof style with "V" shaped rails
- Hangers have four 1-1/4" (32 mm) diameter wheels
- Top and bottom pivots are heavy duty with ball bearing bottom socket assembly for smooth, long lasting operation
- Note: 9890 Series requires 1741 loose pin hinges – included

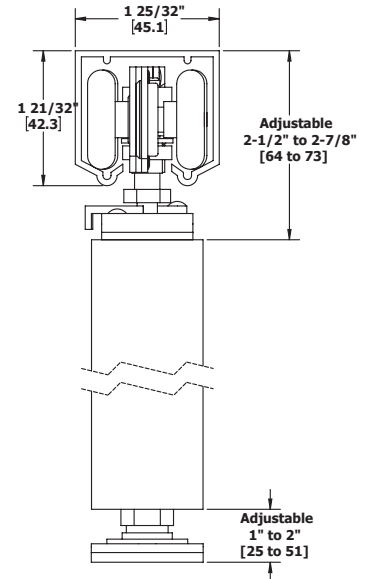
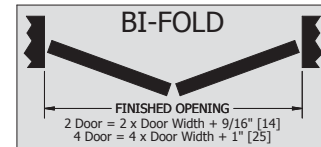

Part Number	Description
9890 Series Set - For two doors Includes one (1) 9801 track, one (1) 9827 hanger, one (1) 9828 pivot, and three (3) 1741 3.5" x 3.5" US2D hinges	
9890-30	Bi-Fold Set - 30" (762 mm) opening for two doors
9890-36	Bi-Fold Set - 36" (914 mm) opening for two doors
9890-48	Bi-Fold Set - 48" (1219 mm) opening for two doors
9891 Series Set - For four doors Includes one (1) 9801 track, one (1) 9827 hanger, one (1) 9828 pivot, and six (6) 1741 3.5" x 3.5" US2D hinges	
9891-48	Bi-Fold Set - 48" (1219 mm) opening for four doors
9891-60	Bi-Fold Set - 60" (1524 mm) opening for four doors
9891-72	Bi-Fold Set - 72" (1829 mm) opening for four doors
9891-96	Bi-Fold Set - 96" (2438 mm) opening for four doors

TRACKS - 0.075" (1.9 mm) thick aluminum

Part Number	Description
Tracks for use with 9890 Series	
9801-72	72" (1829 mm) Aluminum Box Track
9801-96	96" (2438 mm) Aluminum Box Track
9801-120	120" (3048 mm) Aluminum Box Track
9801-144	144" (3658 mm) Aluminum Box Track
9801-192	192" (4877 mm) Aluminum Box Track

Optional Bottom Track 9121 - 9122

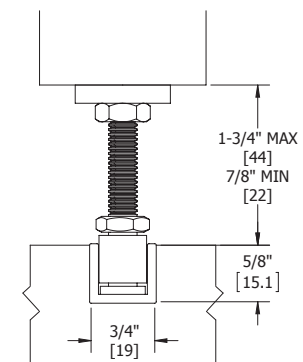

Installation note: Clearance between door bottom and top of 9122 track must be 7/8" (22 mm) minimum to 1-3/4" (44 mm) maximum.





BI-FOLD - 9890 & 9891 TRACK COMPONENTS



9801

Heavy Duty Aluminum Box Track

- Materials: Extruded aluminum
 Gauge: 0.075" (1.9 mm)
 Track: 1-5/8" x 1-3/4"
 (41 mm x 44 mm)
 Lengths: 72" (1829 mm) to 192"
 (4877 mm)
 Notes:
 - For doors up to 250 lbs (113 kg)
 - Jump proof twin channel design



9828

Bi-Fold Pivot Set

- Materials: Zinc plated steel
 Notes:
 - For doors up to 125 lbs (57 kg)
 - Track pivot bearing mounts up inside track - no track cutting required
 - Bottom pivot socket has ball bearing raceway
 - Top and bottom pivots require 1/2" (13 mm) diameter and 1-3/4" (44 mm) deep holes
 - For use with 9801 and 9821 track



1741

Full Mortise, Five Knuckle, Plain Bearing Hinge

- Steel with steel pin (ANSI A5134)
- Reversible
- Square corners
- Removable pin
- 3-1/2" x 3-1/2" (89 mm x 89 mm)
- US2D



9559

Aligner

- Materials: Steel with brass-tone dichromate finish
 Notes:
 - Keeps lead doors aligned when closed
 - Use one on each lead door



9827

Four Wheel Ball Bearing Quick Release Hanger

- Materials: Zinc plated steel
 Wheels: Self aligning to allow consistent contact with track
 Wheel: 1-1/4" (32 mm) diameter
 Notes:
 - For doors up to 125 lbs (57 kg)
 - Pre-lubricated Celcon wheels
 - Ball bearing axles
 - For doors up to 250 lbs (113 kg) for by-pass and pocket applications
 - For use with 9801 track
 - Quick release feature allows easy door hanging and removal



9815

Bumper Stop

- Materials: Zinc plated steel and rubber
 Notes:
 - Fits all Hager track styles except 9101
 - Screws onto track
 - Included in bi-fold sets 9570 and 9890

Optional Components

- | | |
|------|------------------------|
| 9121 | Adj. Bottom Door Guide |
| 9122 | Bottom Guide Channel |
| 9566 | Knob |
| 9567 | Rose |
| 9558 | Wood Knob |

For optional components see pages 59-63